

Operating Instructions Parts List



TF30 and TF50 Lift Table

Note: Owner and operator MUST read and understand this operating instructions before use this lift table.

Thank you for using this lift table. Your lift table is made of high quality steel and is designed for the horizontal lifting and transport of loads on a level, fixed base. For your safety and correct operation, please carefully read this instruction before using it and keep it on file for future reference.

NOTE: All of the information reported herein is based on data available at the moment of printing. We reserves the right to modify our own products at any moment without notice and incurring in any sanction. So, it is suggested to always verify possible updates.

1. WARNINGS

- 1、 DO NOT put foot or hand in scissors mechanism.
- 2、 DO NOT allow other person to stand in front or behind lift table when it is moving.
- 3、 DO NOT move lift table when table is in raised position. Load could fall down.
- 4、 DO NOT enter under table.
- 5、 DO NOT overload lift table.
- 6、 DO NOT put foot in front of rolling wheels, Injury could fall down.
- 7、 WATCH difference of floor level when moving lift table. Load could fall down.
- 8、 DO NOT use lift table on slope or inclined surface, lift table may become uncontrollable and create danger.
- 9、 DO NOT lift people. People could fall down and suffer severe injury.

2. CAUTION

- 1、 Read this operation manual carefully and understand completely operating lift table. Improper operation could create danger.
- 2、 This lift table is a movable lifter designed to lift or lower rated load on table. DO NOT use lift table for other purpose than its intended use.
- 3、 DO NOT allow person to operate lift table that dose not understand its operation.
- 4、 DO NOT lower table too fast. Load could fall down and create danger.
- 5、 KEEP watching the condition of load. Stop operating lift table if load becomes unstable.
- 6、 Braking lift table when sliding load on or off table.
- 7、 DO NOT side or end load. Load must be distributed on at least 80% of table area.
- 8、 DO NOT use lift table with unstable, unbalanced loosely load.
- 9、 Practice maintenance work according to service instructions.
- 10、 DO NOT modify lift table without manufacturers written consent.
- 11、 REMOVE load from table and use safety stopper to prevent table from lowering when servicing lift table.
- 12、 This lift table is not designed to be water resistant. Use lift table under dry condition.

3. DAILY INSPECTION

Daily inspection is effective to find the malfunction or fault on lift table. Check lift table on the following points before operation .

- (1) Check for scratch, bending or cracking on the lift table.
- (2) Check if there is any oil leakage from the cylinder.
- (3) Check the vertical creep of the table.
- (4) Check the smooth movement of the wheels.

- (5) Check the function of brake.
- (6) Check if all the bolts and nuts are tightened firmly.

CAUTION: DO NOT use lift table if any malfunction or fault is found.

4. OPERATING LIFT TABLE

4-1. How to use the brake.

CAUTION: Brake lift when not moving it in order to prevent sudden movement.

The brake is equipped with the swivel caster on the right side.

- (1) Brake the wheel, press the brake pedal.
- (2) Release the brake, lift up the brake pedal.

4-2. Lifting the table

WARNING

1. DO NOT overload lift table. Stay within its rated capacity.
 2. DO NOT side or end. Load must be distributed on at least 80% of table area.
- Press the lifting pedal several times until the table reaches the desired position. The table does not elevate after reaching the highest position even if the lifting pedal is pressed. The table lowers slightly after reaching the highest position.

MAXIMUM CAPACITY OF TABLE	
TF 30	TF 50
300Kg	500Kg

NOTE: The hydraulic cylinder is designed to hold table. As is the nature of hydraulic system, table lowers very slowly over an extended period of time. Please note the table does not stay at the same position indefinitely.

4-3. Lowering table

WARNING: DO NOT put foot or hand in scissors mechanism

- Pull the control handle make table down..

5. Specifications

Model	Capacity (kg)	Table (mm)	Table Height (mm)	Wheel (mm)	Weight (Kg)
TF30	300	815X500/850X500	285-880	Φ125	77
TF50	500	815X500/850X500	285-880	Φ125	81

- USA type before /. European type behind /.

6. Service Instructions

6-1. Lubricate each point described below every month:

6-2. Change hydraulic oil every 12 months.

Lubricating Points

- (1) Fitting of cylinder---Oil
- (2) Roller friction surface---Grease
- (3) Link pin ---Oil
- (4) Pedal fitting point---Oil
- (5) Grease nipple---Grease

7. Part List of Table

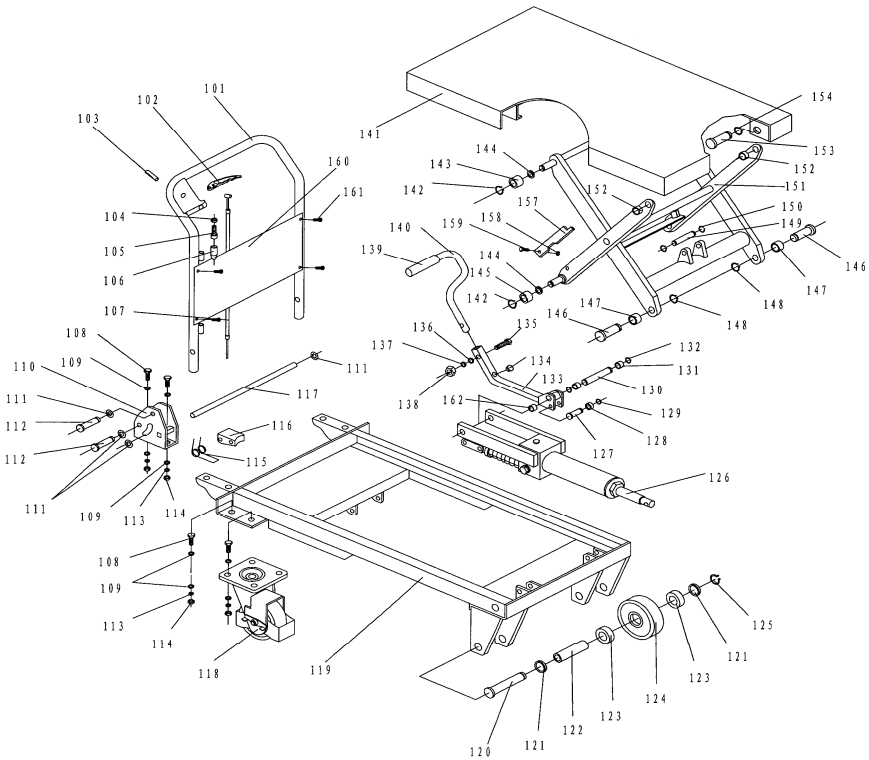

No	Description	Qty.	No	Description	Qty.
101	Handle Grip	1	131	Washer	2
102	Control Handle	1	132	Retaining Ring	2
103	Elastic Pin	1	133	Connecting Rod	1
104	Nut	1	134	Cushion	1
105	Bolt with Hole	1	135	Bolt	1
106	Jacket	1	136	Washer	1
107	Pull Rod	1	137	Elastic Washer	1
108	Bolt	12	138	Nut	1
109	Washer	12	139	Protecting Cover	1
110	Seat of Grip	2	140	Pedal Bar	1
111	Retaining Ring	6	141	Table	1
112	Pin	4	142	Retaining Ring	4
113	Elastic Washer	12	143	Roller	2
114	Nut	12	144	Washer	4
115	Spring	2	145	Roller	2
116	Cushion	2	146	Pin	2
117	Long Shaft	1	147	Bushing	2
118	Universal Wheel	2	148	Retaining Ring	2
119	Frame	1	149	Pin	1
120	Pin	2	150	Retaining Ring	2
121	Washer	4	151	Fork Arm	1
122	Axle	2	152	Bushing	2
123	Bearing	4	153	Pin	2
124	Wheel	2	154	Retaining Ring	2
125	Retaining Ring	2	157	Support Plank	2
126	Pump Unit	1	158	Nut	2
127	Pin	1	159	Screw	2
128	Washer	1	160	Protecting board	1
129	Retaining Ring	1	161	Bolt	4
130	Pin	1	162	Bushing	2

8. Part List of Pump

TF50

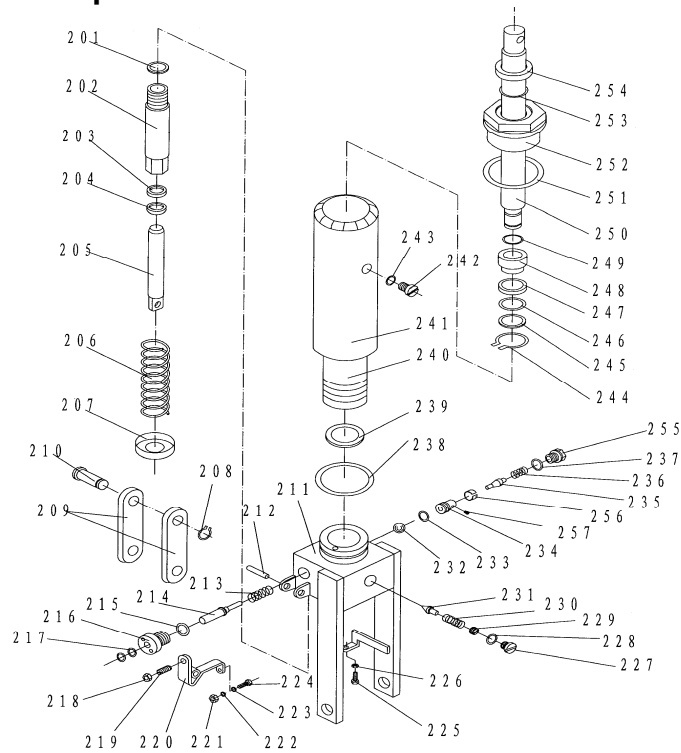

No	Description	Quantity	No	Description	Quantity
201	Seal Washer	1	230	Spring	1
202	Pump Cylinder	1	231	Spindle of Safety Valve	1
203	Dust Ring	1	232	Steel Ball	1
204	Y - Seal	1	233	O-Ring	1
205	Pump Piston	1	234	Seat of Pumping Valve	1
206	Spring	1	235	Spindle of Pumping Valve	1
207	Spring Cap	1	236	Spring	1
208	Retaining Ring	1	237	Seal Washer	1
209	Joint Plate	2	238	O - Ring	1
210	Pin	1	239	Seal Washer	1
211	Pump Body	1	240	Cylinder	1
212	Elastic Pin	1	241	Housing	1
213	Spring	1	242	Bolt	1
214	Strike Pin	1	243	Seal Washer	1
215	Seal Washer	1	244	Retaining Ring	1
216	Axle Sleeve	1	245	Washer	1
217	O - Ring	2	246	O - Ring	1
218	Nut	1	247	Cup Packing	1
219	Screw	1	248	Piston	1
220	Lever Plate	1	249	O - Ring	1
221	Nut	1	250	Piston Rod	1
222	Elastic Washer	1	251	Seal Washer	1
223	Washer	1	252	Cylinder Cap	1
224	Bolt with Hole	1	253	O - Ring	1
225	Bolt with Hole	1	254	Dust Ring	1
226	Nut	1	255	Plug	1
227	Plug	1	256	Liquid Throttle Sheath	1
228	O - Ring	1	257	Bolt	1
229	Adjusting Bolt	1			

9. Part List of Pump

TF30

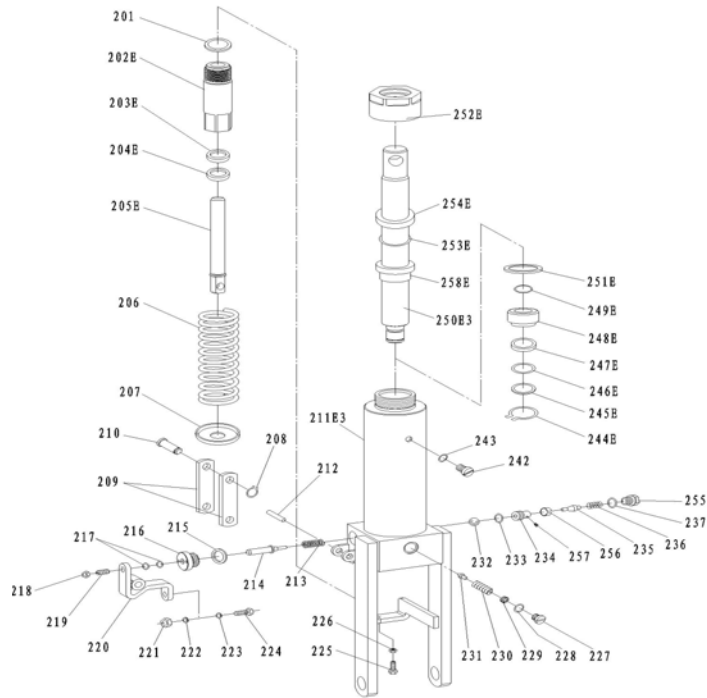

No	Description	Quantity	No	Description	Quantity
201	Seal Washer	1	228	O-Ring	1
202E	Pump Cylinder	1	229	Adjusting Bolt	1
203E	Dust Ring	1	230	Spring	1
204E	Y-Seal	1	231	Spindle of Safety Valve	1
205E	Pump Piston	1	232	Steel Ball	1
206	Spring	1	233	O-Ring	1
207	Spring Cap	1	234	Seat of Pumping Valve	1
208	Retaining Ring	1	235	Spindle of Pumping Valve	1
209	Joint Plate	2	236	Spring	1
210	Pin	1	237	Seal Washer	1
211E3	Pump Body	1	242	Bolt	1
212	Elastic Pin	1	243	Seal Washer	1
213	Spring	1	244E	Retaining Ring	1
214	Strke Pin	1	245E	Washer	1
215	Seal Washer	1	246E	O-Ring	1
216	Axle Sleeve	1	247E	Cup Packing	1
217	O-Ring	2	248E	Piston	1
218	Nut	1	249E	O-Ring	1
219	Screw	1	250E3	Piston Rod	1
220	Lever Plate	1	251E	Seal Washer	1
221	Nut	1	252E	Cylinder Cap	1
222	Elastic Washer	1	253E	O-Ring	1
223	Washer	1	254E	Dust Ring	1
224	Bolt With Hole	1	255	Plug	1
225	Bolt With Hole	1	256	Liquid Throttle Sheath	1
226	Nut	1	257	Bolt	1
227	Plug	1	258E	Sleeve	1

ATTENTION:

1. The worn batteries and accumulators were solid wastes with danger. They are harmful to our health and environment. To avoid polluting with the leaking liquid, we should put the replacements into a special and leak-tight container. To avoid the hurt to people, it should be put away from the place people lived and worked with a warning sticker. The collected worn batteries and accumulators should be handed in to a competent institution according to the local statute.
2. The waste packages should be sorted and put into solid dustbins according to the materials and be collected disposal by local special environment protection bureau. To avoid pollution, it's forbidden to throw away the wastes random.
3. To avoid leaking during the use of the products, the user should prepare some absorbable materials (scraps of wooden or dry duster cloth) to absorb the leaking oil in time. To avoid second pollution to the environment, the used absorbable materials should be handed in to the special department in term of the local statute.