

Operating Instructions

Parts List



Hand Stacker

1.0T/1.6M

Note: Owner and operator MUST read and understand this operating instructions before use this hand stacker.

Date: March , 2012

Welcome to use our hand stacker. Your stacker is made of high quality steel and was designed to give a durable, reliable and easy to use product. For your safety and correct operation, please carefully read this instruction book and warnings on the stacker before using it.

NOTE: All of the information reported herein is based on data available at the moment of printing. The factory reserves the right to modify its own products at any moment without notice and incurring in any sanction. So, it is suggested to always verify possible updates.

1. STRUCTURAL DATA FORM

	TYPE I (Adjusted fork)	TYPE II (Fixed fork)
Capacity	1000 kg	
Max. Fork Height	1600 mm	
Min. Fork Height	85 ± 2mm	
Fork Length	900mm	1150 mm
Size of fork	150x60mm	160x60mm
Fork Width(outside)	330~740mm	550 mm
Fork Width(inside)	30~440mm	230 mm
Over Height	1980mm	
Over Width	775mm	715mm

2. SAFETY GUIDANCE

- 2.1 Operator should read all warning signs and instructions here and on the stacker before using it.
- 2.2 Do not operate an hand stacker unless you are familiar with it and have been trained or authorized to do so.
- 2.3 Do not operate an hand stacker unless you have checked its condition. Give special attention to the wheels, the handle, the guide frame, the pilot wheel, the doorframe, etc.
- 2.4 Do not use on a slopping ground.
- 2.5 Do not take up any people on the forks.
- 2.6 The operator had better take on gloves for labor protecting.
- 2.7 When the goods have been transported or lifted, all people should be away form the forks for 600mm.
- 2.8 Do not load over maximum capacity.
- 2.9 The weight of goods should be distributed on the two forks, do not use only one fork. The center of gravity of goods should be in the center of two forks.
- 2.10 People forbid to stand under the forks.
- 2.11 Do not move the hand stacker when the goods are lifted to the height more than 300mm.
- 2.12 At other special condition or place, the operator should be carefully to operate the hand stacker.

3. MAINTENANCE

3.1 Hydraulic oil

Please check the oil level every six months. The oil can be hydraulic oil: **ISO VG32**, its viscosity should be 32cSt at 40°C, total volume is about 3.0lt.

3.2 Daily check and maintenance

It is necessary to check the hand stacker daily. Special attention should be paid to the wheels, the axles, as thread, rags, etc., it may block the wheels, the fork and the mast should be checked, too. The forks should be unloaded and lowered in the lowest position when the job is over.

3.3 Lubrication

Use motor oil or grease to lubricate all movable parts.

3.4 Remove the air

The air maybe enter the hydraulic pump during the transportation after the customer buys it. It will cause the piston rod to fail to keep up the raised height. The air can be removed in the following way: pull the control handle(F108) up and move handle(F110) up and down for several times.

4. TO ADJUST RELEASE DEVICE

On the draw-bar of this hand stacker, you can find the control handle (F108) which can be regulated in three positions:

LOWER = to lower the forks;

NEUTRAL = to move the load,

LIFT = to raise the fork.

These three positions have been pre-positied at the factory. If however they have been changed, you can adjust according to following step:

- 4.1 If the forks elevate while pumping in the **NEUTRAL** position, turn the adjusting nut (F114) on the adjusting bolt (F113) clockwise or turn the adjusting screw (F227) clockwise until pumping action does not raise the forks and the **NEUTRAL** position functions properly.
- 4.2 If the forks descend while pumping in the **NEUTRAL** position, turn the nut (F114) or the screw (F227) counter-clockwise until the forks do not lower.
- 4.3 If the forks do not descent when the control handle (F108) is in the **LOWER** position, turn the nut (F114) or the screw (F227) clockwise until raising the control handle (F108) lowers the forks. Then check the **NEUTRAL** position according to item 4.1 and 4.2 to be sure the nut (F114) and the screw (F227) is in the proper position.
- 4.4 If the forks do not elevate while pumping in the **LIFT** position, turn the nut (F114) or the screw (F227) counter-clockwise until the forks elevate while pumping in the **LIFT** position. Then

check the **LOWER** and **NEUTRAL** position according to item 4.1, 4.2 and 4.3.

5. TROUBLES SHOOTING

No	Trouble	Clause	Fixing Methods
1	The forks cannot be up the max. height.	- The hydraulic oil is not enough.	- Pour in the oil.
2	The forks can not be lifted up.	- Without hydraulic oil. - The oil has impurities. - The nut (F114) is too high or the screw (F227) is too close, keep the pumping valve open. - Air come into the hydraulic oil.	- Fill in the oil. - Change the oil. - Adjust the nut (F114) or the screw (F227) .(see item 4.4) - Banish the air.(see item 3.4)
3	The forks can not be descended.	- The piston rod(253) or pump body(223) or the mast (F301G) is deformed resulting from loading slanting to one side or over-loading. - The fork was kept in the high position for long time with piston rod bared to arise in rusting and jamming of the rod. - The adjusting nut (F114) or the screw (F227) is not in the correct position. - The rollers (F318) are not lubricated.	- Replace it. - Keeping the fork in the lowest position if not using, and pay more attention to lubricate the rod. - Adjust the nut (F114) or the screw (F227). (see item 4.3) - Lubricate its.
4	Leaks	- Sealing parts worn or damaged. - Some part cracked or worn into small.	- Replace with the new one. - Replace with the new one.
5	The fork descends without the release valve worked.	- The impurities in the oil cause the release valve to be unable to close tight. - Some parts of hydraulic system is cracked or bored. - Air come into the oil. - Sealing parts worn or damaged. - The adjusting nut (F114) or the screw (F227) is not in the correct position.	- Replace with new oil. - Inspect and replace the waste parts. -Banish the air. (See item 3.4) - Replace with the new one. - Adjusting the nut (F114) or the screw (F227). (See item 4.2)

NOTE: DO NOT ATTEMPT TO REPAIR THE HAND STACKER UNLESS YOU ARE TRAINED AND AUTHORIZED TO DO SO.

HANDLE

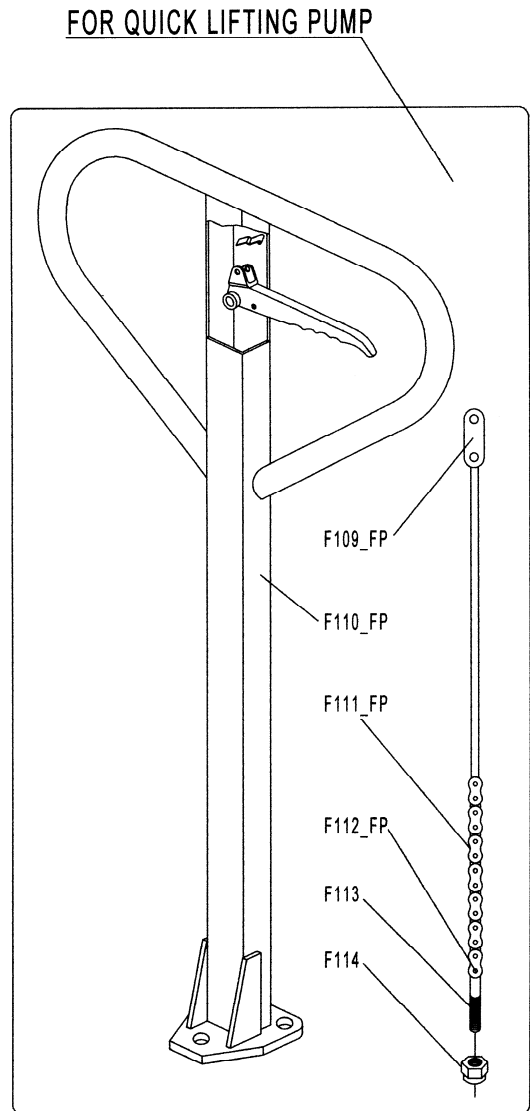
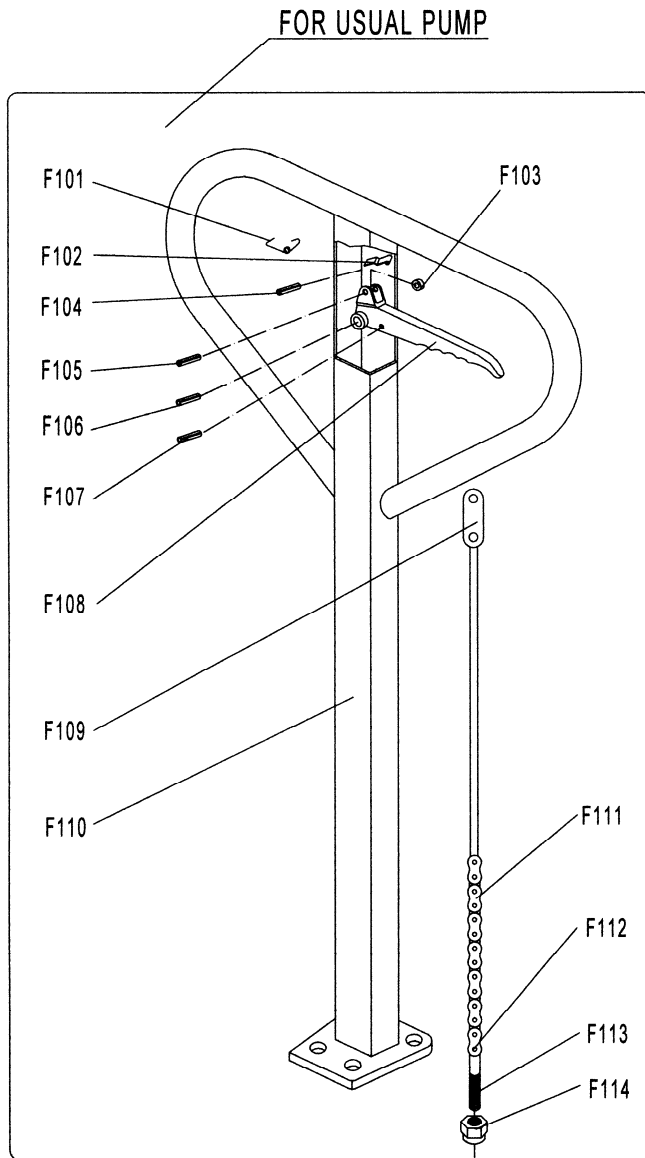

No.	Description	Qty.	Remark	No.	Description	Qty.	Remark
F101	Spring	1		F109	Pull Rod	1	Only for USUAL PUMP
F102	Blade Spring	1		F110	Handle	1	
F103	Roller	1		F111	Chain	1	
F104	Elastic Pin	1		F112	Pin	1	
F105	Elastic Pin	1		F109_FP	Pull Rod	1	For QUICK LIFTING PUMP and TYPE III PUMP
F106	Elastic Pin	1		F110_FP	Handle	1	
F107	Elastic Pin	1		F111_FP	Chain	1	
F108	Control Handle	1		F112_FP	Pin	1	
F113	Adjusting Bolt	1					
F114	Adjust Nut	1					

USUAL PUMP

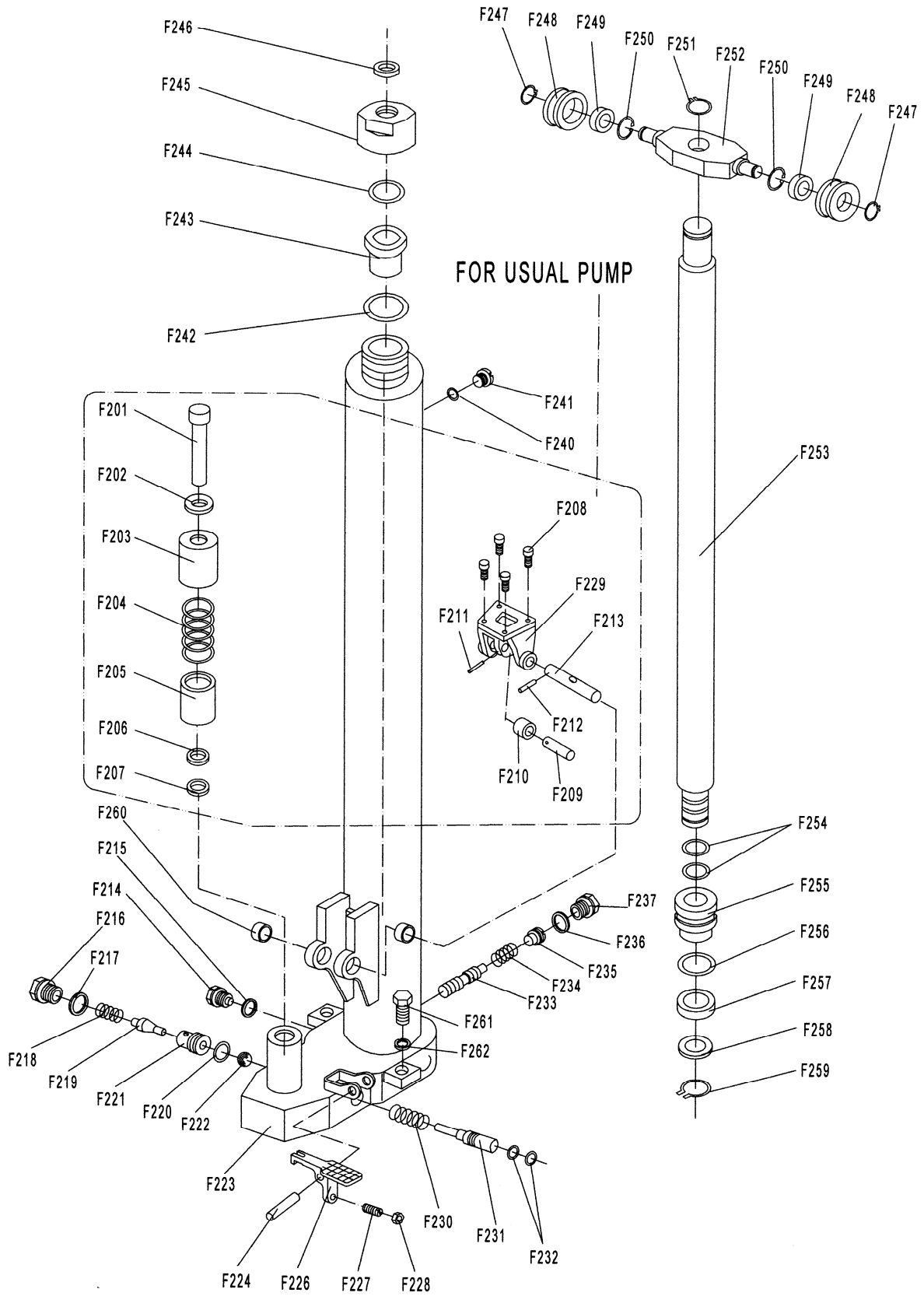

QUICK LIFTING PUMP

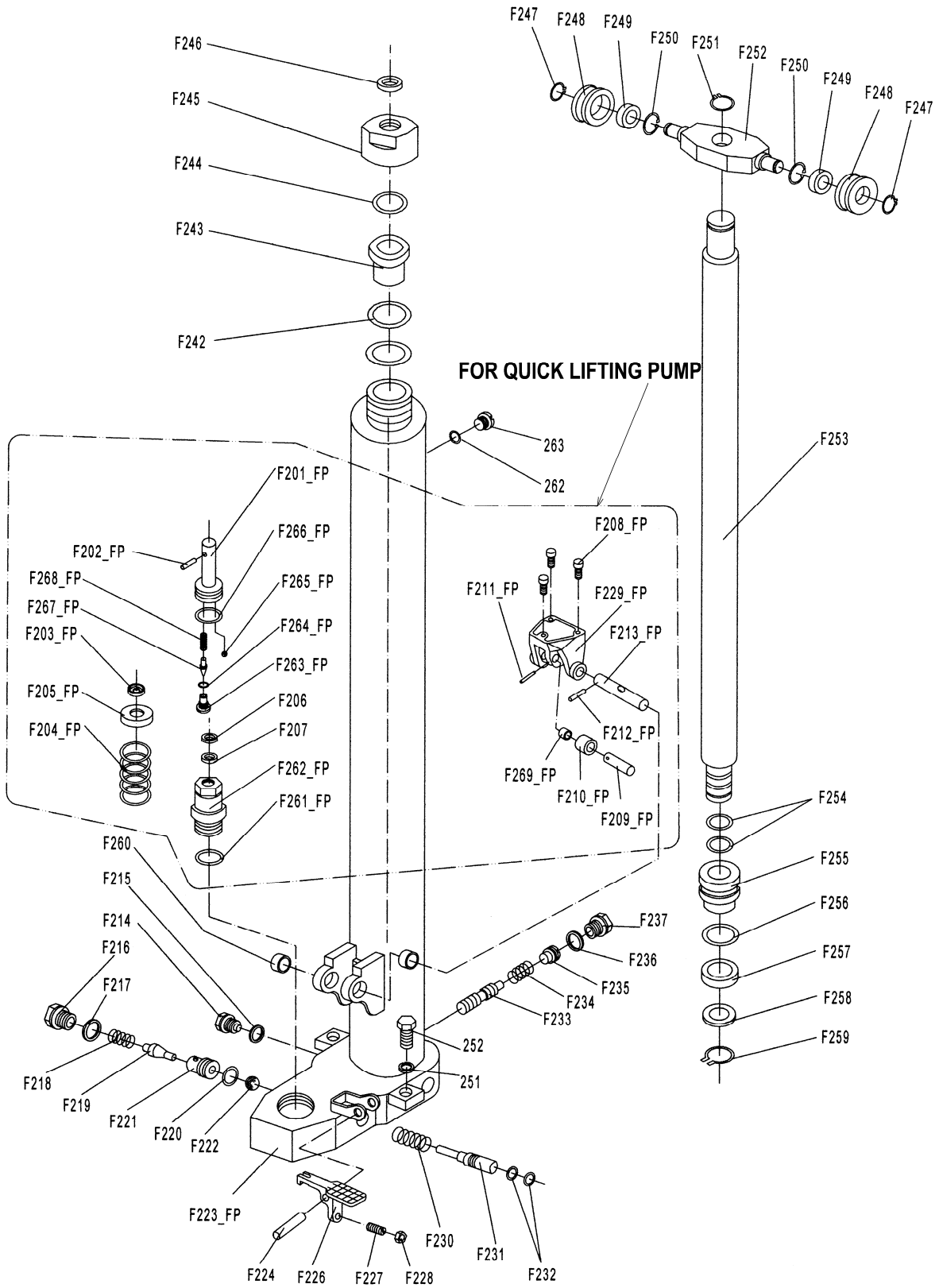

TYPE III PUMP

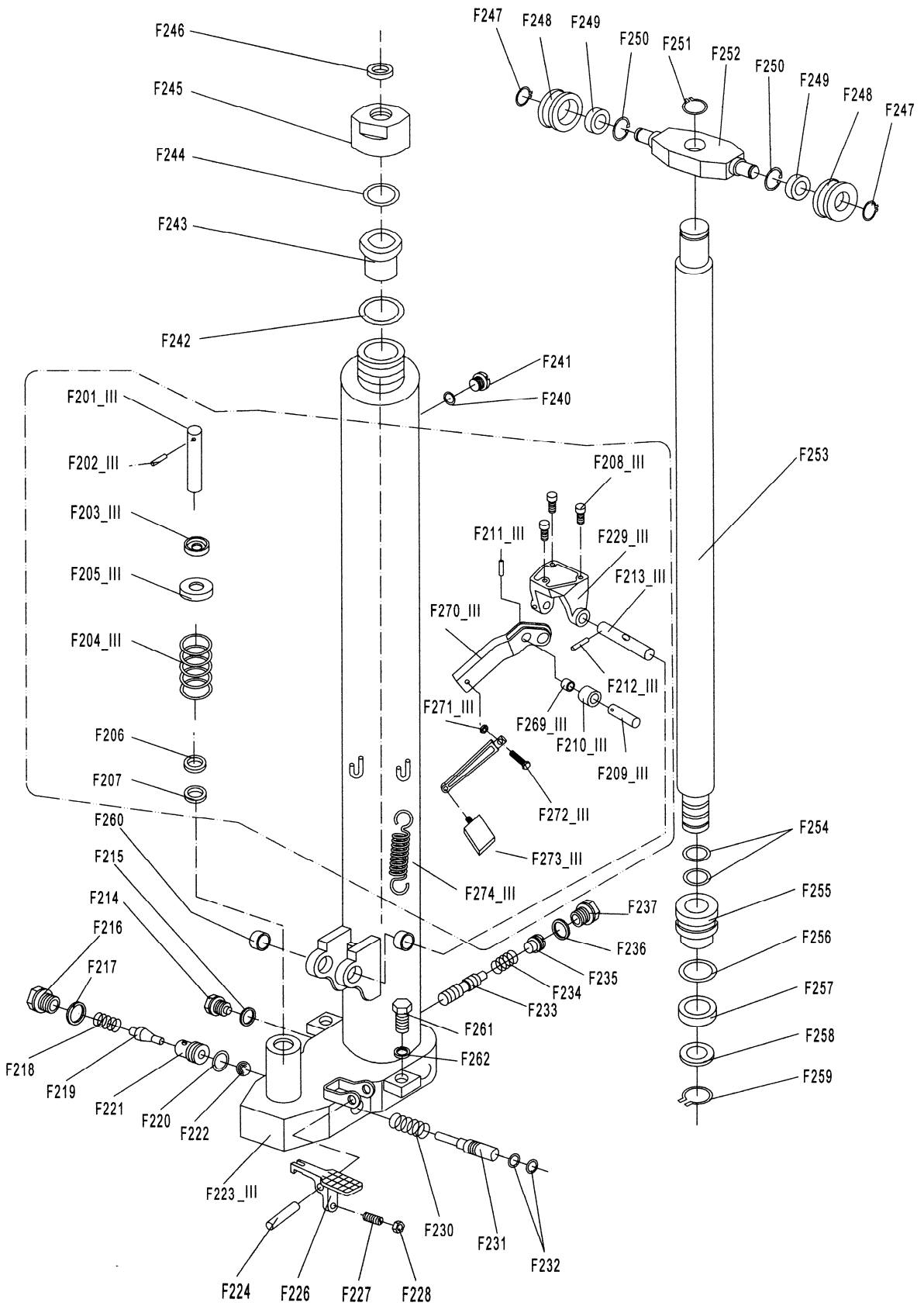

PUMP PART LIST

No.	Description	Qty.	Remark	No.	Description	Qty.	Remark	
F201	Pump Piston Rod	1	Only For USUAL PUMP	F206	Dust Ring	1		
F202	Washer	1		F207	Seal	1		
F203	Upper Cap of Spring	1		F214	Bolt	1		
F204	Spring	1		F215	Seal Washer	1		
F205	Lower Cap of Spring	1		F216	Spring	1		
F208	Bolt	4		F217	Seal Washer	1		
F209	Shaft	1		F218	Spring	1		
F210	Pressure Roller	1		F219	Valve Spindle of Pump	1		
F211	Elastic Pin	1		F220	O-Ring	1		
F212	Elastic Pin	1		F221	Seat of Pump Valve	1		
F213	Axle with hole	1		F222	Steel Ball	1		
F223	Body of Pump	1		F224	Shaft	1		
F229	Bracket	1		F225	Locking Ring	1		
F201_FP	Pump Piston Rod	1		Only For Quick Lifting Pump	F226	Lever Plate	1	
F202_FP	Pin	1			F227	Screw	1	
F203_FP	Cap of Pin	1	F228		Nut	1		
F204_FP	Spring	1	F230		Spring	1		
F205_FP	Cap of Spring	1	F231		Release Valve Pin	1		
F208_FP	Bolt	3	F232		O-Ring	2		
F209_FP	Shaft	1	F233		Pin to Adjust Velocity	1		
F210_FP	Pressure Roller	1	F234		Spring	1		
F211_FP	Elastic Pin	1	F235		Adjust Screw	1		
F212_FP	Elastic Pin	1	F236		Seal Washer	1		
F213_FP	Axle with hole	1	F237		Bolt	1		
F223_FP	Body of Pump	1	F238		Bolt	2		
F229_FP	Bracket	1	F239		Elastic Washer	2		
F261_FP	O - Ring	1	F240		Seal Washer	1		
F262_FP	Pumping Cylinder	1	F241		Screw	1		
F263_FP	Screw	1	F242		Seal Washer	1		
F264_FP	O - Ring	1	F243		Sleeve	1		
F265_FP	Steel Ball	1	F244		O-Ring	1		
F266_FP	O - Ring	1	F245		Cover with Screw	1		
F267_FP	Valve Spindle	1	F246		Dust Ring	1		
F268_FP	Spring	1	F247		Locking Ring	2		
F269_FP	Bushing	1	F248		Roller for Chain	2		
F201_III	Pump Piston Rod	1	Only for TYPE III PUMP		F249	Bearing	2	
F202_III	Pin	1			F250	Locking Ring	2	
F203_III	Cap of Pin	1			F251	Locking Ring	1	
F204_III	Spring	1		F252	Holding Plate	1		
F205_III	Cap of Spring	1		F253	Lifting Piston Rod	1		
F208_III	Bolt	3		F254	O-Ring	2		
F209_III	Shaft	1		F255	Piston	1		
F210_III	Pressure Roller	1		F256	O-Ring	1		
F211_III	Elastic Pin	1		F257	Seal	1		
F212_III	Elastic Pin	1		F258	Washer	1		
F213_III	Axle with hole	1		F259	Locking Ring	1		
F223_III	Body of Pump	1		F260	Bushing	2		
F229_III	Bracket	1						
F269_III	Bushing	1						
F270_III	Lever of Pedal	1						
F271_III	Nut	1						
F272_III	Bolt	1						
F273_III	Pedal	1						
F274_III	Spring	2						

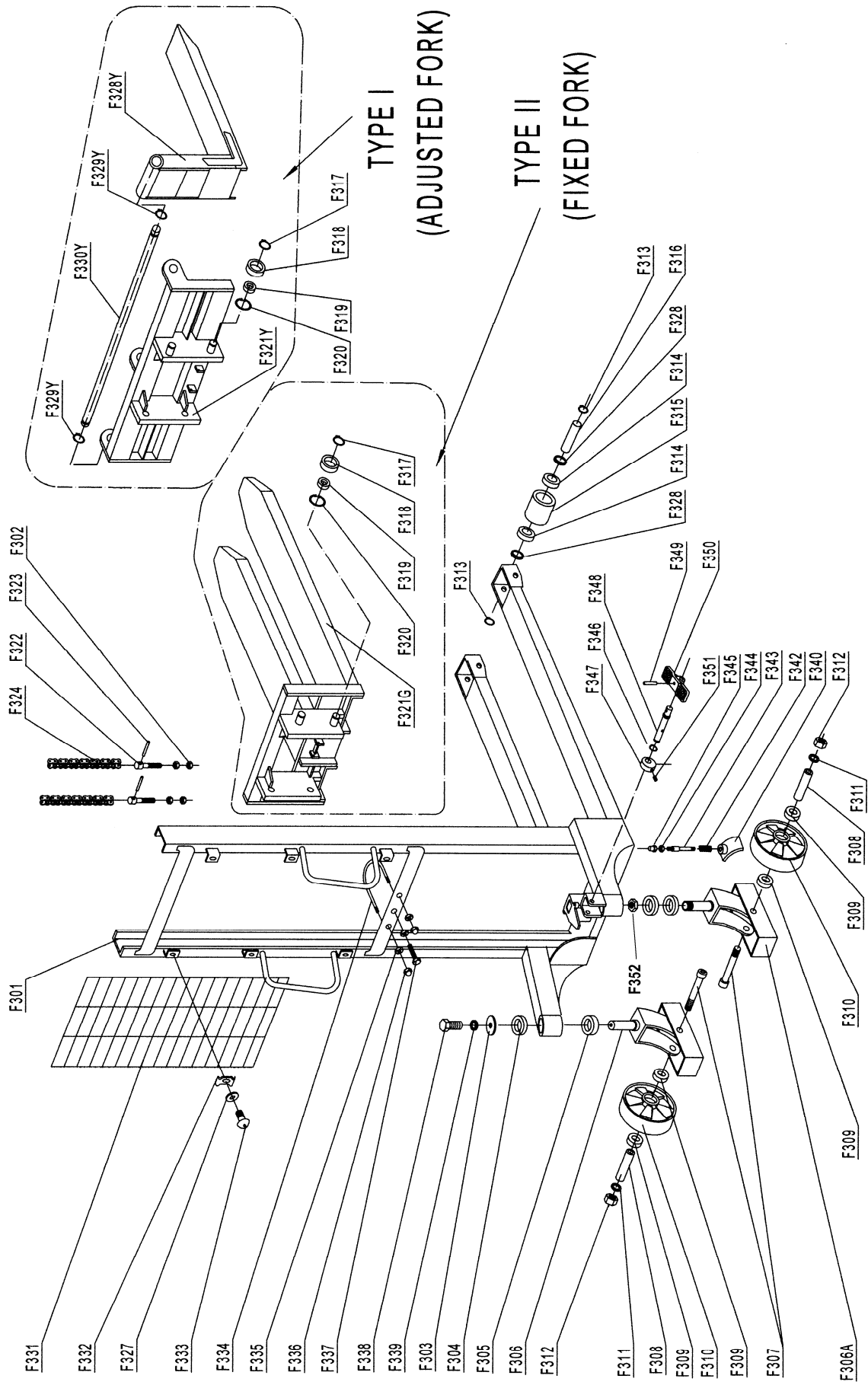

Part List of Mast

No.	Description	Qty.	Remark
F301Y	Mast	1	For TYPE I (Adjusted Fork)
F301G	Mast	1	For TYPE II (Fixed Fork)
F302	Nut	4	
F303	Cap	2	
F304	Bearing	2	
F305	Bearing	2	
F306	Frame of Wheel	1	
F306A	Frame of Wheel with Brake	1	
F307	Screw	2	
F308	Axle of Wheel	2	
F309	Bearing	4	
F310	Wheel	2	
F311	Elastic Washer	2	
F312	Nut	2	
F313	Locking Ring	2	
F314	Bearing	4	
F315	Loading Roller	2	
F316	Axle of Loading Roller	2	
F317	Locking Ring	4	
F318	Roller	4	
F319	Bearing	4	
F320	Locking Ring	4	
F321G	Fork	2	For TYPE II (Fixed Fork)
F322	Bolt	2	
F323	Pin	2	
F324	Chain	2	
F325	Linking Chain	2	
F326	Plate of Chain	2	
F327	Locking Plate	2	
F321Y	Frame of Fork	1	For TYPE I (Adjusted Fork)
F328Y	Fork	2	
F329Y	Retaining Ring	2	
F330Y	Long Axle	1	
F331	Reticulation	1	
F332	Washer	4	
F333	Screw	4	
F334	Hoop to Holding Pump	1	
F335	Nut	3	
F336	Nut	2	
F337	Bolt	1	
F338	Bolt	1	
F339	Elastic Washer	1	
F340	Brake Plate	1	
F341	Locking Ring	1	
F342	Spring	1	
F343	Bolt	1	
F344	Nut	1	
F345	Nut	1	
F346	Locking Ring	1	
F347	Cam	1	
F348	Pin	1	
F349	Elastic Pin	1	
F350	Footplate	1	
F351	Screw	1	
F352	Nut	1	