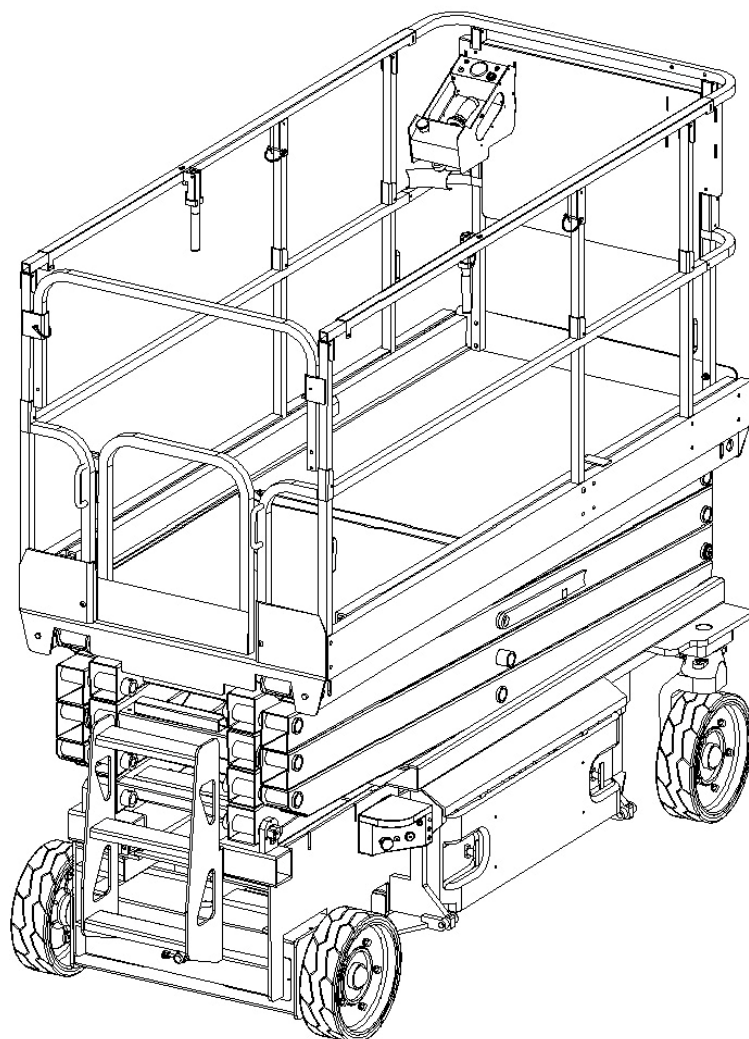


**⚠ WARNING**

**Must read before using this manual  
And the various warning label attached!  
Attention preservation for future use!**



# **Operation and Safety Manual**

**AWPS23.56/AWPS46.79/AWPS46.96**

## **Electric scissor lifts**

FOREWORD .....	3
SAFETY ALERT SYMBOLS AND SAFETY SIGNAL WORDS.....	4
1. SAFETY PRECAUTIONS .....	5
1.1 GENERAL .....	5
1.2 PRE-OPERATION .....	6
1.3 OPERATION .....	7
1.4 TOWING, LIFTING, AND HAULING .....	12
1.5 MAINTENANCE.....	12
2. USER RESPONSIBILITIES, MACHINE PREPARATION & INSPECTION.....	14
2.1 PERSONNEL TRAINING.....	14
2.2 PREPARATION, INSPECTION, AND MAINTENANCE .....	15
3. USER RESPONSIBILITIES AND MACHINE CONTROLS.....	20
3.1 GENERAL .....	20
3.2 PERSONNEL TRAINING.....	20
3.3 OPERATING CHARACTERISTICS AND LIMITATIONS.....	22
3.4 CONTROLS AND INDICATORS .....	22
3.5 SIGNS.....	27
4. MACHINE OPERATION .....	31
4.1 DESCRIPTION .....	31
4.2 OPERATION .....	31
4.3 RAISING AND LOWERING .....	31
4.4 STEERING.....	34
4.5 DRIVING .....	34
4.6 PARKING AND STOWING .....	35
4.7 BATTERY CHARGING.....	36
4.8 PLATFORM LOADING.....	37
4.9 SAFETY PROP .....	38
4.10 TIE DOWN/LIFT LUGS .....	38
4.11 LIFTING.....	38
4.12 TOWING.....	39
5. EMERGENCY PROCEDURES.....	40
5.1 GENERAL .....	40
5.2 EMERGENCY OPERATION.....	40
6. GENERAL SPECIFICATIONS AND OPERATOR MAINTENANCE.....	42
6.1 INTRODUCTION.....	42
6.2 OPERATING SPECIFICATIONS.....	42
6.3 CRITICAL STABILITY WEIGHTS .....	45
6.5 TIRES AND WHEELS .....	48
Appendix 1 list of wearing parts .....	49
Appendix 2 Inspection and maintenance records .....	50

## **FOREWORD**

This manual is a very important tool! Keep it with the machine at all times.

The purpose of this manual is to provide owners, users, operators, lessors, and lessees with the precautions and operating procedures essential for the safe and proper machine operation for its intended purpose.

All of the information reported herein is based on data available at the moment of printing. Our products are constantly being developed and renewed, we reserves the right to modify our own products at any moment without notice and incurring in any sanction. So, it is suggested to always verify possible updates.

## SAFETY ALERT SYMBOLS AND SAFETY SIGNAL WORDS



—This is the Safety Alert Symbol. It is used to alert you to the potential personal injury hazards. Obey all safety messages that follow this symbol to avoid possible injury or death



—INDICATES AN IMMINENTLY HAZARDOUS SITUATION. IF NOT AVOIDED, WILL RESULT IN SERIOUS INJURY OR DEATH. THIS DECAL WILL HAVE A RED BACKGROUND.



—INDICATES A POTENTIALITY HAZARDOUS SITUATION. IF NOT AVOIDED, COULD RESULT IN SERIOUS INJURY OR DEATH. THIS DECAL WILL HAVE AN ORANGE BACKGROUND.



—INDICATES A POTENTIALITY HAZARDOUS SITUATION. IF NOT AVOIDED, MAY RESULT IN MINOR OR MODERATE INJURY. IT MAY ALSO ALERT AGAINST UNSAFE PRACTICES. THIS DECAL WILL HAVE A YELLOW BACKGROUND.

### **NOTICE**

—AND PERSONNEL SAFETY OR PROTECTION OF PROPERTY DIRECTLY OR INDIRECTLY RELATED INFORMATION OR COMPANY POLICY.



THE ELECTRIC PALLET TRUCK CANNOT BE USED IN POTENTIALLY EXPLOSIVE ATMOSPHERES!



THIS PRODUCT MUST COMPLY WITH ALL SAFETY RELATED BULLETINS. CONTACT NOBLELIFT EQUIPMENT JOINT STOCK CO.,LTD. OR THE LOCAL AUTHORIZED NOBLELIFT REPRESENTATIVE FOR INFORMATION REGARDING SAFETYRELATED BULLETINS WHICH MAY HAVE BEEN ISSUED FOR THIS PRODUCT.

### **NOTICE**

NOBLELIFT EQUIPMENT JOINT STOCK CO.,LTD. SENDS SAFETY RELATED BULLETINS TO THE OWNER OF RECORD OF THIS MACHINE. CONTACT NOBLELIFT EQUIPMENT JOINT STOCK CO.,LTD. TO ENSURE THAT THE CURRENT OWNER RECORDS ARE UPDATED AND ACCURATE.

### **NOTICE**

NOBLELIFT EQUIPMENT JOINT STOCK CO.,LTD. MUST BE NOTIFIED IMMEDIATELY IN ALL INSTANCES WHERE NOBLELIFT PRODUCTS HAVE BEEN INVOLVED IN AN ACCIDENT INVOLVING BODILY INJURY OR DEATH OF PERSONNEL OR WHEN SUBSTANTIAL DAMAGE HAS OCCURRED TO PERSONAL PROPERTY OR THE NOBLELIFT PRODUCT.

**For:**

- Accident Reporting
- Product Safety Publications
- Current Owner Updates
- Questions Regarding Product Safety
- Standards and Regulations Compliance Information
- Questions Regarding Special Product Applications
- Questions Regarding Product Modifications

**Contact:**

**NOBLELIFT EQUIPMENT JOINT STOCK CO. LTD.**  
No.528, Jingyi Road Economic Development  
Zone, Changxing, Zhejiang, China  
Tel:0572-6210811 Fax:0572-6128212  
or Your Local NOBLELIFT Office

## **1. SAFETY PRECAUTIONS**

### **1.1 GENERAL**

This section outlines the necessary precautions for proper and safe machine usage and maintenance. In order to promote proper machine usage, it is mandatory that a daily routine is established based on the content of this manual. A maintenance program, using the information provided in this manual and the Service and Maintenance Manual, must also be established by a qualified person and must be followed to ensure that the machine is safe to operate.

The owner/user/operator/lessor/lessee of the machine should not accept operating responsibility until this manual has been read, training is accomplished, and operation of the machine has been completed under the supervision of an experienced and qualified operator.

These sections contain the responsibilities of the owner, user, operator, lessor, and lessee concerning safety, training, inspection, maintenance, application, and operation. If there are any questions with regard to safety, training, inspection, maintenance, application, and operation, please contact NOBLELIFT Industries, Inc.

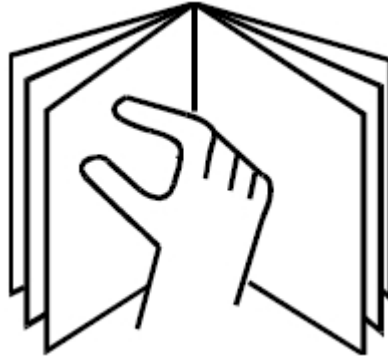
### **WARNING**

**FAILURE TO COMPLY WITH THE SAFETY PRECAUTIONS LISTED IN THIS MANUAL COULD RESULT IN MACHINE DAMAGE, PROPERTY DAMAGE, PERSONAL INJURY OR DEATH.**

## 1.2 PRE-OPERATION

### Operator Training and Knowledge

- The Operators and Safety Manual must be read in its entirety before operating the machine.



- An operator must not accept operating responsibilities until adequate training has been given by competent and authorized persons.
- Allow only those authorized and qualified personnel to operate the machine who have demonstrated that they understand the safe and proper operation and maintenance of the unit.
- Read, understand, and obey all DANGERS, WARNINGS, CAUTIONS, and operating instructions on the machine and in this manual.
- Ensure that the machine is to be used in a manner which is within the scope of its intended application as determined by NOBLIFT
- All operating personnel must be familiar with the emergency controls and emergency operation of the machine as specified in this manual.
- Read, understand, and obey all applicable employer, local, and governmental regulations as they pertain to your utilization and application of the machine.

### Workplace Inspection

- Precautions to avoid all hazards in the work area must be taken by the user before operation of the machine.
- Do not operate or raise the platform from a position on trucks, trailers, railway cars, floating vessels, scaffolds or other equipment unless the application is approved in writing by NOBLIFT.
- Before operation, check work area for overhead hazards such as electric lines, bridge cranes, and other potential overhead obstructions.
- Check floor surfaces for holes, bumps, drop-offs, obstructions, debris, concealed holes, and other potential hazards.

- Check the work area for hazardous locations. Do not operate the machine in hazardous environments unless approved for that purpose by NOBLIFT.
- Ensure that the ground conditions are adequate to support the maximum tire load indicated on the tire load decals located on the chassis adjacent to each wheel.
- Do not operate the machine when wind conditions exceed 28 mph (12.5 m/s).
- This machine can be operated in nominal ambient temperatures of 0° F to 104° F (-20°C to 40°C). Consult NOBLIFT to optimize operation outside of this temperature range.

## Machine Inspection

- Do not operate this machine until the inspections and functional checks have been performed as specified in Section 2 of this manual.
- Do not operate this machine until it has been serviced and maintained according to the maintenance and inspection requirements as specified in the machine's Service and Maintenance Manual.
- Ensure all safety devices are operating properly. Modification of these devices is a safety violation.

### **WARNING**

MODIFICATION OR ALTERATION OF AN AERIAL WORK PLATFORM SHALL BE MADE ONLY WITH PRIOR WRITTEN PERMISSION FROM THE MANUFACTURER.

- Do not operate any machine on which the safety or instruction placards or decals are missing or illegible.
- Check the machine for modifications to original components. Ensure that any modifications have been approved by NOBLIFT.
- Avoid accumulation of debris on platform deck. Keep mud, oil, grease, and other slippery substances from footwear and platform deck.

## 1.3 OPERATION

### General

- Do not use the machine for any purpose other than positioning personnel, their tools, and equipment.
- Before operation, the user must be familiar with the machine capabilities and operating characteristics of all functions.
- Never operate a malfunctioning machine. If a malfunction occurs, shut down the

machine. Remove the unit from service and notify the proper authorities.

- Do not remove, modify, or disable any safety devices.
- Never slam a control switch or lever through neutral to an opposite direction. Always return switch to neutral and stop before moving the switch to the next function. Operate controls with slow and even pressure.
- Do not allow personnel to tamper with or operate the machine from the ground with personnel in the platform, except in an emergency.
- Do not carry materials directly on platform railing unless approved by NOBLIFT.
- When two or more persons are in the platform, the operator shall be responsible for all machine operations.
- Always ensure that power tools are properly stowed and never left hanging by their cord from the platform work area.
- Do not assist a stuck or disabled machine by pushing or pulling except by pulling at the chassis tie-down lugs.
- The extension of the platform only in the lowest position to extend the operation.
- Stow scissor arm assembly and shut off all power before leaving machine.
- The machine has according to EN280:2001 + A2:2009 the braking, overload and function testing.

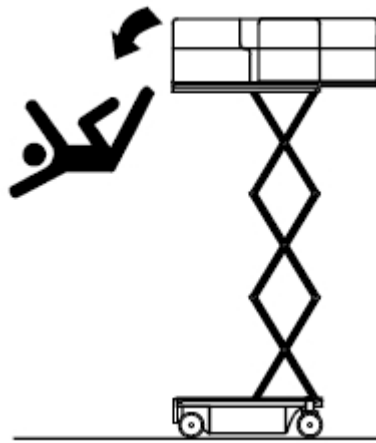
### Trip and Fall Hazards

- NOBLIFT Industries, Inc. recommends that all persons in the platform wear a full body harness with a lanyard attached to an authorized lanyard anchorage point while operating this machine. For further information regarding fall protection requirements on NOBLIFT products, contact NOBLIFT Industries, Inc.



- Prior to operation, ensure all gates and rails are fastened and secured in their proper position. Identify the designated lanyard anchorage point(s) at the platform and securely attach the lanyard. Attach only one (1) lanyard per lanyard anchorage point.

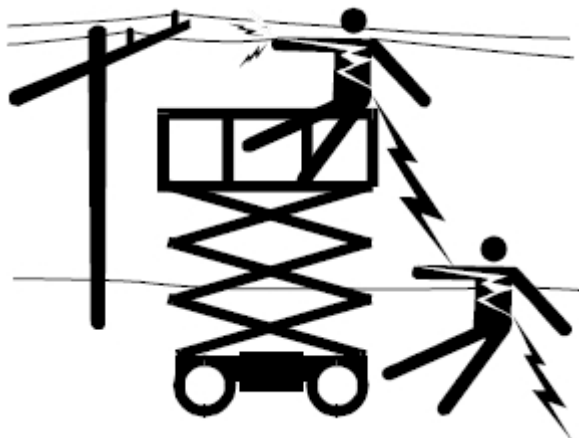
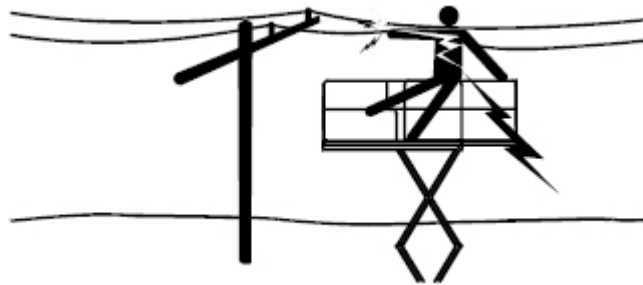




- Keep both feet firmly positioned on the platform floor at all times. Never position ladders, boxes, steps, planks, or similar items on unit to provide additional reach for any purpose.
- Never use the scissor arm assembly to gain access to or leave the platform.
- Use extreme caution when entering or leaving platform. Ensure that the scissor arm assembly is fully lowered. Face the machine when entering or leaving the platform. Always maintain “three point contact” with the machine, using two hands and one foot or two feet and one hand at all times during entry and exit.
- Keep oil, mud, and slippery substances cleaned from footwear and the platform floor.

### Electrocution Hazards

- This machine is not insulated and does not provide protection from contact or proximity to electrical current.



- Maintain safe clearance from electrical lines, apparatus, or any energized (exposed or insulated) parts in accordance with the Minimum Approach Distance (M.A.D.) as specified in Table 1-1.
- Allow for machine movement and electrical line swaying.

**Table 1-1. Minimum Approach Distances (M.A.D.)**

Voltage Range (Phase to Phase)	MINIMUM APPROACH DISTANCE in Feet (Meters)
0 to 50KV	10 (3)
Over 50 KV to 200 KV	15 (5)
Over 200 KV to 350 KV	20 (6)
Over 350 KV to 500 KV	25 (8)
Over 500 KV to 750 KV	35 (11)
Over 750 KV to 1000 KV	45 (14)
<b>NOTE: This requirement shall apply except where employer, local or governmental regulations are more stringent.</b>	

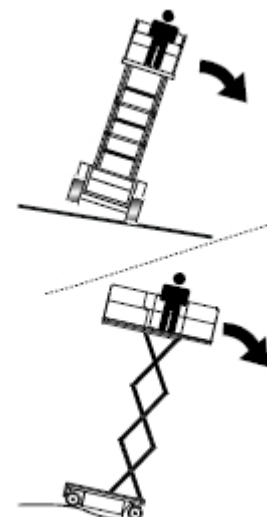
- Maintain a clearance of at least 10 ft (3 m) between any part of the machine and its occupants, their tools, and their equipment from any electrical line or apparatus carrying up to 50,000 volts. One foot additional clearance is required for every additional 30,000 volts or less.
- The minimum approach distance may be reduced if insulating barriers are installed to prevent contact, and the barriers are rated for the voltage of the line being guarded. These barriers shall not be part of (or attached to) the machine. The minimum approach distance shall be reduced to a distance within the designed working dimensions of the insulating barrier. This determination shall be made by a qualified person in accordance with the employer, local, or governmental requirements for work practices near energized equipment.

**⚠ DANGER**

DO NOT MANEUVER MACHINE OR PERSONNEL INSIDE PROHIBITED ZONE (M.A.D.). ASSUME ALL ELECTRICAL PARTS AND WIRING ARE ENERGIZED UNLESS KNOWN OTHERWISE

**Tipping Hazards**

- Ensure that the ground conditions are adequate to support the maximum tire load indicated on the tire load decals located on the chassis adjacent to each wheel. Do not travel on unsupported surfaces.
- The user should be familiar with the driving surface before driving. Do not exceed the allowable sideslope and grade

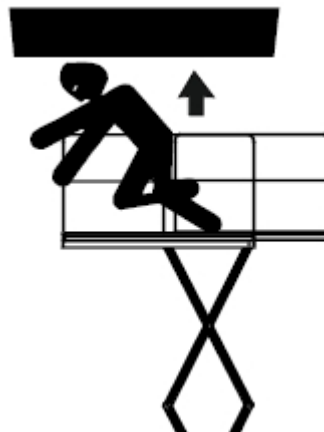


while driving.

- Do not elevate platform or drive with platform elevated while on or near a sloping, uneven, or soft surface. Ensure machine is positioned on a firm, level and smooth surface before elevating platform or driving with the platform in the elevated position.
- Before driving on floors, bridges, trucks, and other surfaces, check allowable capacity of the surfaces.
- Never exceed the maximum work load as specified on the platform. Keep all loads within the confines of the platform, unless authorized by NOBLIFT.
- Keep the chassis of the machine a minimum of 0.6 m (2 ft) from holes, bumps, drop-offs, obstructions, debris, concealed holes, and other potential hazards at the ground level.
- Never attempt to use the machine as a crane. Do not tie off machine to any adjacent structure. Never attach wire, cable, or any similar items to platform.
- Do not cover the platform sides or carry large surface-area items in the platform when operating outdoors. The addition of such items increases the exposed wind area of the machine.
- Do not increase the platform size with unauthorized deck extensions or attachments.
- If scissor arm assembly or platform is caught so that one or more wheels are off the ground, all persons must be removed before attempting to free the machine. Use cranes, forklift trucks, or other appropriate equipment to stabilize machine and remove personnel.

## Crushing and Collision Hazards

- Approved head gear must be worn by all operating and ground personnel.
- Keep hands and limbs out of the scissor arm assembly during operation.
- Watch for obstructions around machine and overhead when driving. Check clearances above, on sides, and bottom of platform when lifting or lowering platform.



- During operation, keep all body parts inside platform railing.
- Always post a lookout when driving in areas where vision is obstructed.
- Keep non-operating personnel at least 1.8 m (6 ft) away from machine during all driving operations.
- Under all travel conditions, the operator must limit travel speed according to conditions of ground surface, congestion, visibility, slope, location of personnel, and other factors causing hazards of collision or injury to personnel.
- Be aware of stopping distances in all drive speeds. When driving in high speed, switch to low speed before stopping. Travel grades in low speed only.
- Do not use high speed drive in restricted or close quarters or when driving in reverse.
- Exercise extreme caution at all times to prevent obstacles from striking or interfering with operating controls and persons in the platform.
- Ensure that operators of other overhead and floor level machines are aware of the aerial work platform's presence. Disconnect power to overhead cranes. Barricade floor area if necessary.
- Avoid operating over ground personnel. Warn personnel not to work, stand, or walk under a raised platform. Position barricades on floor as necessary.

## **1.4 TOWING, LIFTING, AND HAULING**

- Never allow personnel in platform while towing, lifting, or hauling.
- This machine should not be towed, except in the event of emergency, malfunction, power failure, or loading/unloading. Refer to emergency towing procedures.
- Ensure platform is fully retracted and completely empty of tools prior to towing, lifting or hauling.
- When lifting machine with a forklift, position forks only at designated areas of the machine. Lift with a forklift of adequate capacity.
- Refer to Section 4 for lifting information.

## **1.5 MAINTENANCE**

### General

This section contains general safety precautions which must be observed during maintenance of this machine. Additional precautions to be observed during machine maintenance are inserted at the appropriate points in this manual and in the Service and Maintenance Manual. It is of utmost importance that maintenance personnel pay strict attention to these precautions to avoid possible injury to personnel or damage to the machine or property. A maintenance program must be established by a qualified person and must be followed to ensure that the machine is safe.

## Maintenance Hazards

- Shut off power to all controls and ensure that all operating systems are secured from inadvertent motion prior to performing any adjustments or repairs.
- Never work under an elevated platform until it has been fully lowered to the full down position, if possible, or otherwise supported and restrained from movement with appropriate safety props, blocking, or overhead supports.
- Always relieve hydraulic pressure from all hydraulic circuits before loosening or removing hydraulic components.
- Always disconnect batteries when servicing electrical components or when performing welding on the machine.
- Shut down the engine (if equipped) while fuel tanks are being filled.
- Ensure replacement parts or components are identical or equivalent to original parts or components.
- Never attempt to move heavy parts without the aid of a mechanical device. Do not allow heavy objects to rest in an unstable position. Ensure adequate support is provided when raising components of the machine.
- Remove all rings, watches, and jewelry when performing any maintenance. Do not wear loose fitting clothing or long hair unrestrained which may become caught or entangled in equipment.
- Use only clean approved non-flammable cleaning solvents.
- Never alter, remove, or substitute any items such as counterweights, tires, batteries, platforms or other items that may reduce or affect the overall weight or stability of the machine.
- Reference the Service and Maintenance Manual for the weights of critical stability items.

### **WARNING**

**MODIFICATION OR ALTERATION OF AN AERIAL WORK PLATFORM SHALL BE MADE ONLY WITH PRIOR WRITTEN PERMISSION FROM THE MANUFACTURER.**

## Battery Hazards

- Always disconnect batteries when servicing electrical components or when performing welding on the machine.
- Do not allow smoking, open flame, or sparks near battery during charging or servicing.
- Do not contact tools or other metal objects across the battery terminals.
- Always wear hand, eye, and face protection when servicing batteries. Ensure that battery acid does not come in contact with skin or clothing.

### **WARNING**

**BATTERY FLUID IS HIGHLY CORROSIVE. AVOID CONTACT WITH SKIN AND CLOTHING AT ALL TIMES. IMMEDIATELY RINSE ANY CONTACTED AREA WITH CLEAN WATER AND SEEK MEDICAL ATTENTION.**

- Charge batteries only in a well ventilated area.
- Avoid overfilling the battery fluid level. Add distilled water to batteries only after the batteries are fully charged.

## **2. USER RESPONSIBILITIES, MACHINE PREPARATION &**

### **INSPECTION**

#### **2.1 PERSONNEL TRAINING**

The aerial platform is a personnel handling device; so it is necessary that it be operated and maintained only by trained personnel.

Persons under the influence of drugs or alcohol or who are subject to seizures, dizziness or loss of physical control must not operate this machine.

#### Operator Training

Operator training must cover:

1. Use and limitations of the controls in the platform and at the ground, emergency controls and safety systems.
2. Control labels, instructions, and warnings on the machine.

3. Rules of the employer and government regulations.
4. Use of approved fall protection device.
5. Enough knowledge of the mechanical operation of the machine to recognize a malfunction or potential malfunction.
6. The safest means to operate the machine where overhead obstructions, other moving equipment, and obstacles, depressions, holes, drop-offs.
7. Means to avoid the hazards of unprotected electrical conductors.
8. Specific job requirements or machine application.

### Training Supervision

Training must be done under the supervision of a qualified person in an open area free of obstructions until the trainee has developed the ability to safely control and operate the machine.

### Operator Responsibility

The operator must be instructed that he/she has the responsibility and authority to shut down the machine in case of a malfunction or other unsafe condition of either the machine or the job site.

## 2.2 PREPARATION, INSPECTION, AND MAINTENANCE

The following table covers the periodic machine inspections and maintenance recommended by NOBLIFT Industries, Inc.. Consult local regulations for further requirements for aerial work platforms. The frequency of inspections and maintenance must be increased as necessary when the machine is used in a harsh or hostile environment, if the machine is used with increased frequency, or if the machine is used in a severe manner.

### **NOTICE**

**NOBLIFT INDUSTRIES, INC. RECOGNIZES A FACTORY-CERTIFIED SERVICE TECHNICIAN AS A PERSON WHO HAS SUCCESSFULLY COMPLETED THE NOBLIFT SERVICE TRAINING SCHOOL FOR THE SPECIFIC NOBLIFT PRODUCT MODEL.**

**Table 2-1. Inspection and Maintenance Table**

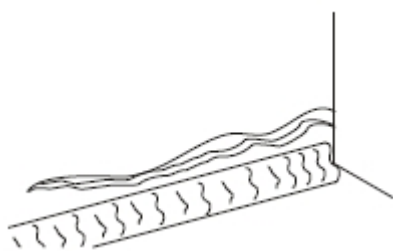
Type	Frequency	Primary Responsibility	Service Qualification	Reference
Pre-Start Inspection	Before using each day; or whenever there's an Operator change	User or Operator	User or Operator	Operator and Safety Manual
Pre-Delivery Inspection (See Note)	Before each sale, lease, or rental delivery.	Owner, Dealer, or User	Qualified Mechanic	Service and Maintenance Manual and applicable inspection form
Frequent Inspection	In service for 3 months or 150 hours, whichever comes first; or Out of service for a period of more than 3 months; or Purchased used.	Owner, Dealer, or User	Qualified Mechanic	Service and Maintenance Manual and applicable inspection form
Annual Machine Inspection	Annually, no later than 13 months from the date of prior inspection.	Owner, Dealer, or User	Factory Certified Service Technician (Recommended)	Service and Maintenance Manual and applicable inspection form
Preventative Maintenance	At intervals as specified in the Service and Maintenance Manual.	Owner, Dealer, or User	Qualified Mechanic	Service and Maintenance Manual

NOTE: Inspection forms are available from NOBLIFT. Use the Service and Maintenance Manual to perform inspections.

### Pre-Start Inspection

The Pre-Start Inspection should include each of the following:

- Cleanliness** – Check all surfaces for leakage (oil, fuel, or battery fluid) or foreign objects. Report any leakage to the proper maintenance personnel.
- Structure** - Inspect the machine structure for dents, damage, weld or parent metal cracks or other discrepancies.



Parent Metal Crack



Weld Crack

- Decals and Placards** – Check all for cleanliness and legibility. Make sure none of the decals and placards are missing. Make sure all illegible decals and placards are cleaned or replaced.
- Operation and Safety Manuals** – Make sure a copy of the Operator and Safety Manual.
- “Walk-Around” Inspection** – Refer to Figure 2-1



6. **Battery** – Charge as required.
7. **Fuel** (Combustion Engine Powered Machines) – Add the proper fuel as necessary.
8. **Engine Oil Supply** (If equipped) - Ensure the engine oil level is at the Full mark on the dipstick and the filler cap is secure.
9. **Fluid Levels** – Check the hydraulic oil level. Ensure hydraulic oil is added as required.
10. **Accessories/Attachments** - Reference the Operator and Safety Manual of each attachment or accessory installed upon the machine for specific inspection, operation, and maintenance instructions.
11. **Function Check** – Once the “Walk-Around” Inspection is complete, perform a functional check of all systems in an area free of overhead and ground level obstructions. Refer to Section 4 for more specific operating instructions.

## Function Check

Perform the Function Check as follows:

1. From the ground control console with no load in the platform:
  - a. Check that all guards protecting the function control switches and controllers are in place.
  - b. Operate all functions and check all limiting and cutout switches.
  - c. Check manual descent.
  - d. Ensure that all machine functions are disabled when the Emergency Stop Button is depressed.
2. From the platform control console:
  - a. Ensure that the control console is firmly secured in the proper location.
  - b. Check that all guards protecting the function control switches and controllers are in place.
  - c. Operate all functions and check all limiting and cutout switches.
  - d. Ensure that all machine functions are disabled when the Emergency Stop Button is depressed.
3. With the platform in the transport (stowed) position:
  - a. Drive the machine on a grade, not to exceed the rated gradeability, and stop to ensure the brakes hold.
  - b. Check the tilt indicator light to ensure proper operation. The light should be

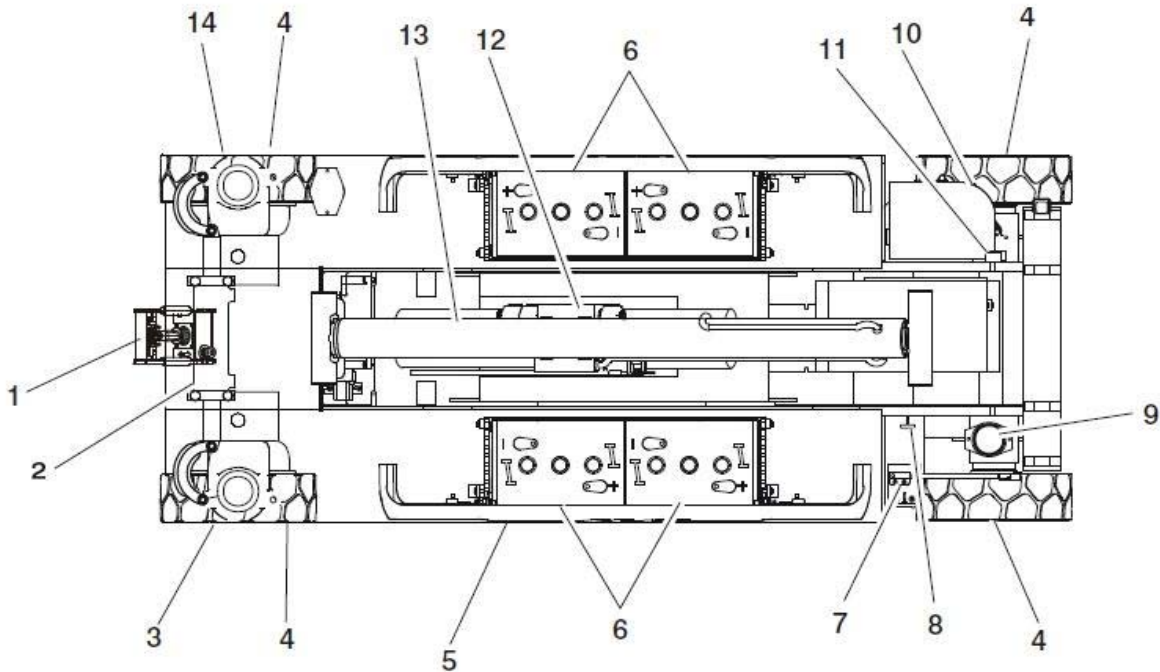
illuminated when tilted.

**Table 2-2. Tilt vs. Height**

Model	Tilt Setting (front to back)	Tilt Setting (side to side)	Maximum Deck Elevation	
			Feet	Meters
	Degrees			
AWPS23.56	2	2	18.4(Full)	5.6
AWPS46.79	2	2	26 (Full)	7.9
AWPS46.96	2	2	31.5 (Full)	9.6

**Table 2-3. High Drive Speed Cutout Height**

Model	High Drive Speed Cutout Height	
AWPS23.56	54 in	1.4m
AWPS46.79	76 in	1.9m
AWPS46.96	76 in	1.9m



**Figure 2-1. Daily Walk-Around Inspection - Sheet 1 of 3**

**General**

Begin the “Walk-Around Inspection” at Item 1, as noted on the diagram. Continue Left (counterclockwise viewed from top) checking each item in sequence for the conditions listed in the following checklist.

**⚠ WARNING**

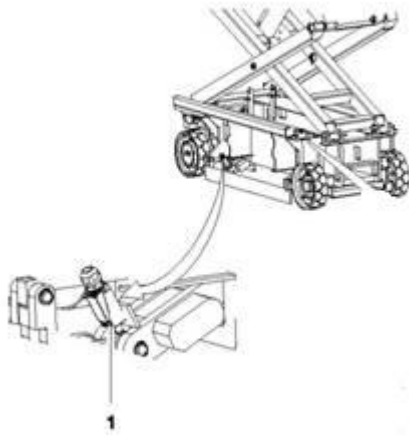
**TO AVOID POSSIBLE INJURY, BE SURE MACHINE POWER IS “OFF” DURING “WALK-AROUND INSPECTION”.**

## **NOTICE**

**DO NOT OVERLOOK VISUAL INSPECTION OF CHASSIS UNDERSIDE. CHECKING THIS AREA OFTEN RESULTS IN DISCOVERY OF CONDITIONS WHICH COULD CAUSE EXTENSIVE MACHINE DAMAGE.**

**NOTE:** *On each item, make sure there are no loose or missing parts, that they are securely fastened, and that no visible damage exists in addition to any other criteria mentioned.*

1. Platform Control Console - Placard secure and legible, control lever and switches return to neutral, control lever lock and emergency stop switch function properly, manual in storage box.
2. Steer Cylinder - See Note
3. Spindle, Tie Rod, Drive Motor and Steer Linkage (left front) - See Note
4. Wheels and Tires - Properly secured, no missing lug nuts. Refer to Section 6, Tires and Wheels. Inspect wheels for damage and corrosion.
5. Pothole Protection System - See Note
6. Battery Compartment - Proper electrolyte level.
7. Proximity Switch - See Note
8. Manual Descent - See Note
9. Beacon - See Note
10. Ground Controls - Placard secure and legible, control switches return to neutral position, emergency stop switch functions properly. Control markings legible.
11. Rotary Angle Switch - See Note
12. Hydraulic Pump/Motor, Control Valve Installation – No unsupported wires or hoses; no damaged or broken wires - See Note
13. Lift Cylinder - See Note
14. Spindle, Tie Rod, Drive Motor and Steer Linkage (left front) - See Note
15. Sizzor Arms, Pivot Pins and Sliding Wear Pads (Not Shown) - See Note
16. Platform/Handrail Installation (Not Shown) - See Note



1、 Pothole Switch (Typical on opposite side of machine)

**Figure 2-2. Switch Location - 2 of 2**

## **3. USER RESPONSIBILITIES AND MACHINE CONTROLS**

### **3.1 GENERAL**

#### **NOTICE**

**SINCE THE MANUFACTURER HAS NO DIRECT CONTROL OVER MACHINE APPLICATION AND OPERATION, CONFORMANCE WITH GOOD SAFETY PRACTICES IN THESE AREAS IS THE RESPONSIBILITY OF THE USER AND HIS OPERATING PERSONNEL.**

This section provides the necessary information needed to understand control functions. Included in this section are the operating characteristics and limitations, and functions and purposes of controls and indicators. It is important that the user read and understand the proper procedures before operating the machine. These procedures will aid in obtaining optimum service life and safe operation.

### **3.2 PERSONNEL TRAINING**

The scissor lift is a personnel handling device; therefore, it is essential that it be operated and maintained only by authorized personnel who have demonstrated that they understand the proper use and maintenance of the machine. It is important that all personnel who are assigned to and responsible for the operation

and maintenance of the machine undergo a thorough training program and check out period in order to become familiar with the characteristics prior to operating the machine.

Persons under the influence of drugs or alcohol or who are subject to seizures, dizziness or loss of physical control must not be permitted to operate the machine.

## Operator Training

Operator training must include instruction in the following:

1. Use and limitations of the platform controls, ground controls, emergency controls and safety systems.
2. Knowledge and understanding of this manual and of the control markings, instructions and warnings on the machine itself.
3. Knowledge and understanding of all safety work rules of the employer and of Federal, State and Local Statutes, including training in the recognition and avoidance of potential hazards in the work place; with particular attention to the work to be performed.
4. Proper use of all required personnel safety equipment.
5. Sufficient knowledge of the mechanical operation of the machine to recognize a malfunction or potential malfunction.
6. The safest means to operate near overhead obstructions, other moving equipment, obstacles, depressions, holes, drop-offs, etc. on the supporting surface.
7. Means to avoid the hazards of unprotected electrical conductors.
8. Any other requirements of a specific job or machine application.

## Training Supervision

Training must be done under the supervision of a qualified operator or supervisor in an open area free of obstructions until the trainee has developed the ability to safely control a scissor lift in congested work locations.

## Operator Responsibility

The operator must be instructed that he has the responsibility and authority to shut down the machine in case of a malfunction or other unsafe condition of either the machine or the job site and to request further information from his supervisor or NOBLIFT Distributor before proceeding.

**NOTE:** *Manufacturer or Dealer will provide qualified persons for training assistance with first unit(s) delivered and thereafter as requested by user or his personnel.*

## 3.3 OPERATING CHARACTERISTICS AND LIMITATIONS

### General

A thorough knowledge of the operating characteristics and limitations of the machine is always the first requirement for any user, regardless of user's experience with similar types of equipment.

### Placards

Important points to remember during operation are provided at the control stations by DANGER, WARNING, CAUTION, IMPORTANT and INSTRUCTION placards. This information is placed at various locations for the express purpose of alerting personnel of potential hazards constituted by the operating characteristics and load limitations of the machine. See foreword for definitions of the above placards.

### Capacities

Raising platform above horizontal with or without any load in platform, is based on the following criteria:

1. Machine is positioned on a smooth, firm and level surface.
2. Load is within manufacturer's rated capacity.
3. All machine systems are functioning properly.

### Stability

This machine, as originally manufactured by NOBLIFT and operated within its rated capacity on a smooth, firm and level supporting surface, provides a stable aerial platform for all platform positions.

## 3.4 CONTROLS AND INDICATORS

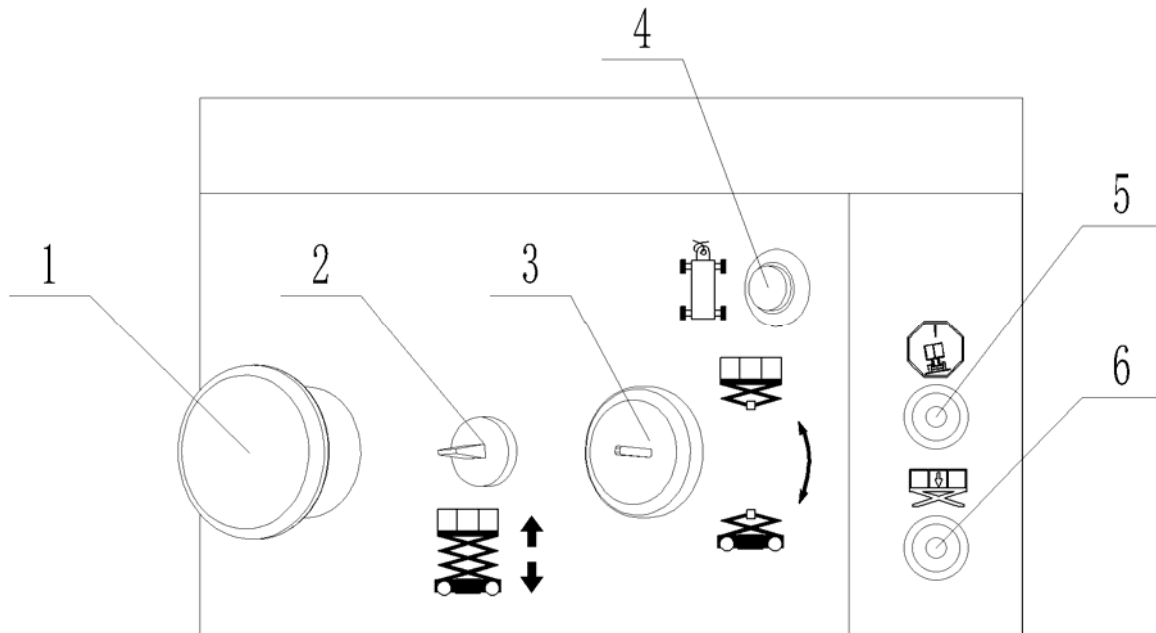
### Ground Control Station



**DO NOT OPERATE FROM GROUND CONTROL STATION WITH PERSONNEL IN THE PLATFORM EXCEPT IN AN EMERGENCY.**

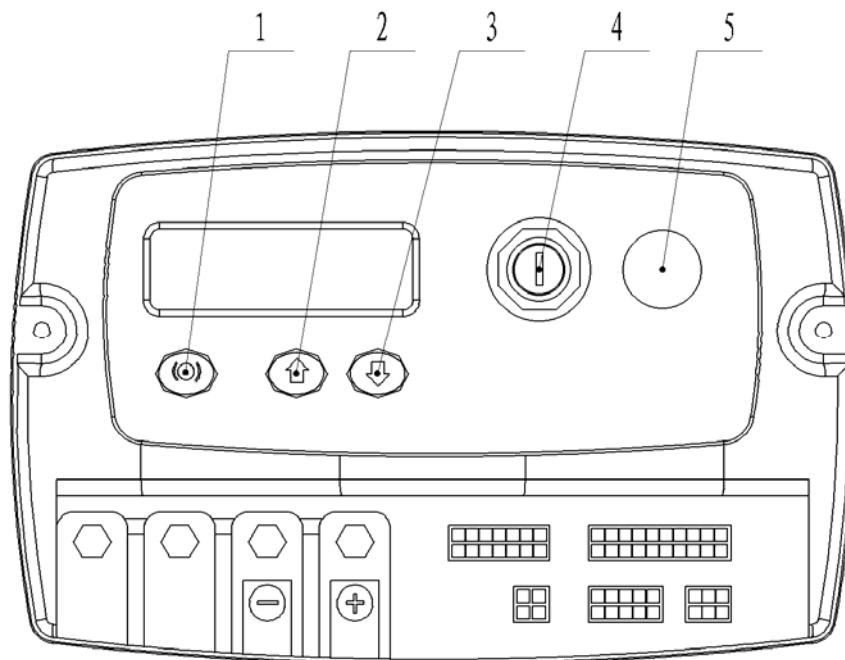
**PERFORM AS MANY PRE-OPERATIONAL CHECKS AND INSPECTIONS FROM THE GROUND CONTROL STATION AS POSSIBLE.**

**NOTE:** *When the machine is shut down for overnight parking or battery charging, the emergency stop and power select switches must be positioned to off to prevent draining the batteries.*



**Figure 3-1. AWPS4679/AWPS4696 Ground Control Station**

- 1、 **Emergency Stop Switch** - A two-position, red, mushroom- shaped emergency stop switch, when positioned to ON with the power selector switch positioned to ground, furnishes operating power to the ground control station. In addition, the switch can be used to turn off power to the function controls in the event of an emergency. Power is turned on by pulling the switch out (on), and is turned off by depressing switch.
- 2、 **Platform Lift/Lower Switch** - A three position, momentary contact Lift control switch provides raising and lowering of the platform when positioned to up or down.
- 3、 **Platform/Ground Control Switch** - A three position, key-operated power select switch supplies operating power to the platform or ground controls, as selected. When positioned to platform, the switch provides power to the emergency stop switch at the platform controls. When positioned to ground, the switch provides power to the ground control. The ground control emergency stop switch provides power to the key switch. With the power select switch in the center off position, power is shut off to both platform and ground controls.
- 4、 **The brakes release button (traction mode selection button)** - Key switch must be chosen to chassis operation mode, and the platform dropped to its lowest level, press the switch, the vehicle brake release
- 5、 **LED-indicator light**-when the machine was something wrong, this light will twinkle
- 6、 **LED-indicator light**-when the machine was something wrong, this light will twinkle



**Figure 3-2. AWPS2356 Ground Control Station**

**1. The brakes release button (traction mode selection button)** - Key switch must be chosen to chassis operation mode, and the platform dropped to its lowest level, press the switch, the vehicle brake release

**2. Platform lift switch** - Pressing this switch, the platform to go up.

**3. Platform drop switch** - Pressing this switch, the platform to go down.

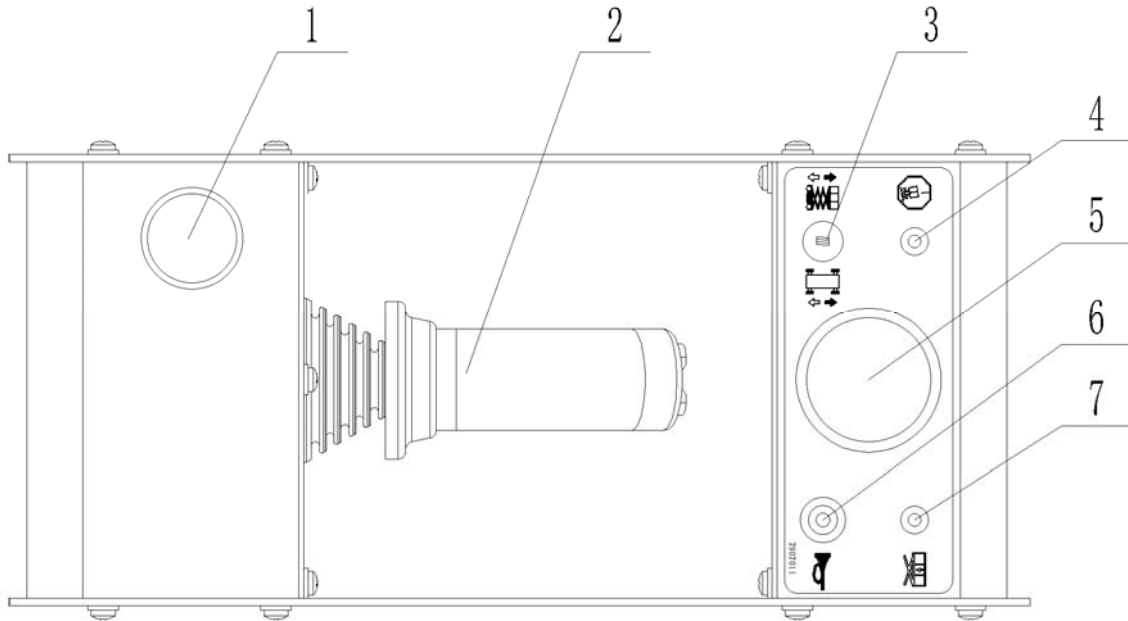
**4. Platform/Ground Control Switch** - A three position, key-operated power select switch supplies operating power to the platform or ground controls, as selected.

When positioned to platform, the switch provides power to the emergency stop switch at the platform controls. When positioned to ground, the switch provides power to the ground control. The ground control emergency stop switch provides power to the key switch. With the power select switch in the center off position, power is shut off to both platform and ground controls.

**5. Emergency Stop Switch** - A two-position, red, mushroom- shaped emergency stop switch, when positioned to ON with the power selector switch positioned to ground, furnishes operating power to the ground control station. In addition, the switch can be used to turn off power to the function controls in the event of an emergency. Power is turned on by pulling the switch out (on), and is turned off by depressing switch.

## **PLATFORM CONTROL STATION**





**Figure 3-3. AWPS4679/AWPS4696 Platform Control Station**

- 1、 **Emergency Stop Switch** - A two-position, red, mushroom-shaped emergency stop switch functions to provide power to the platform control station and also to turn off power to the platform function controls in the event of an emergency. With the Power selector switch positioned to platform, power is turned on by pulling the switch out (on), and is turned off by pushing the switch in (off).
- 2、 **Control Pole** - it used to control three function: lift、steer、drive. After selecting one of the function, control this switch to use the machine.
- 3、 **Lift/Drive Select** - This toggle switch is used to select either drive or lift.
- 4、 **LED-indicator light**-when the machine was something wrong, this light will twinkle
- 5、 **Meter Display** - to display a series of state in present of machine.
- 6、 **Horn** - This push-button switch, when activated, permits the operator to warn jobsite personnel when the machine is operating in the area.
- 7、 **LED-indicator light**-when the machine was something wrong, this light will twinkle

**⚠ CAUTION**

**IF THE TILT INDICATOR WARNING LIGHT OR HORN IS ON WHEN PLATFORM IS RAISED, LOWER PLATFORM COMPLETELY, THEN REPOSITION MACHINE SO THAT IT IS LEVEL BEFORE RAISING**

**PLATFORM.**

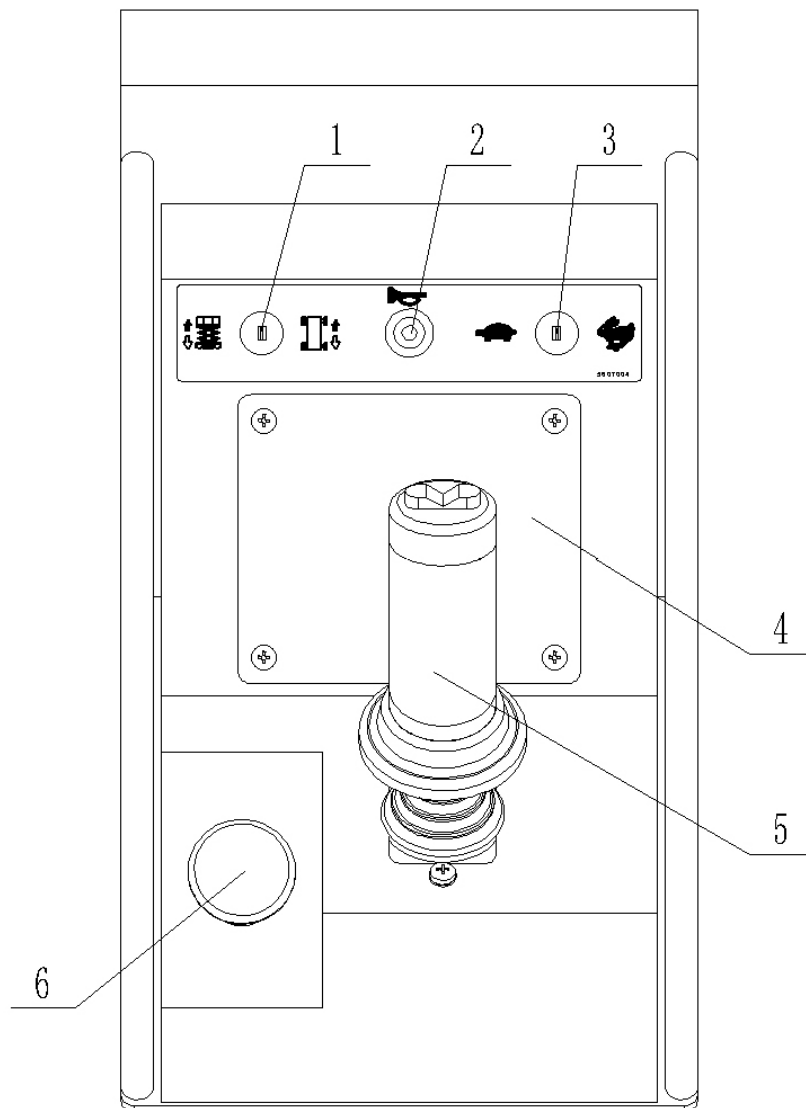
**NOTE:** machines are equipped with a tilt interlock which cuts out drive and lift up functions when chassis is on a slope greater than what is allowable for the machine and the platform is elevated.

**⚠ CAUTION**

**DO NOT “LOWER” WITHOUT COMPLETELY RETRACTING THE PLATFORM EXTENSION**

**⚠ CAUTION**

**DO NOT OPERATE MACHINE IF HIGH DRIVE SPEED OPERATES WHEN PLATFORM IS RAISED ABOVE THE STOWED POSITION.**



**Figure 3-4. AWPS2356 Platform Control Station**

**1.Lift/Drive Select** - This toggle switch is used to select either drive or lift.

**2. Horn** - This push-button switch, when activated, permits the operator to warn jobsite personnel when the machine is operating in the area.

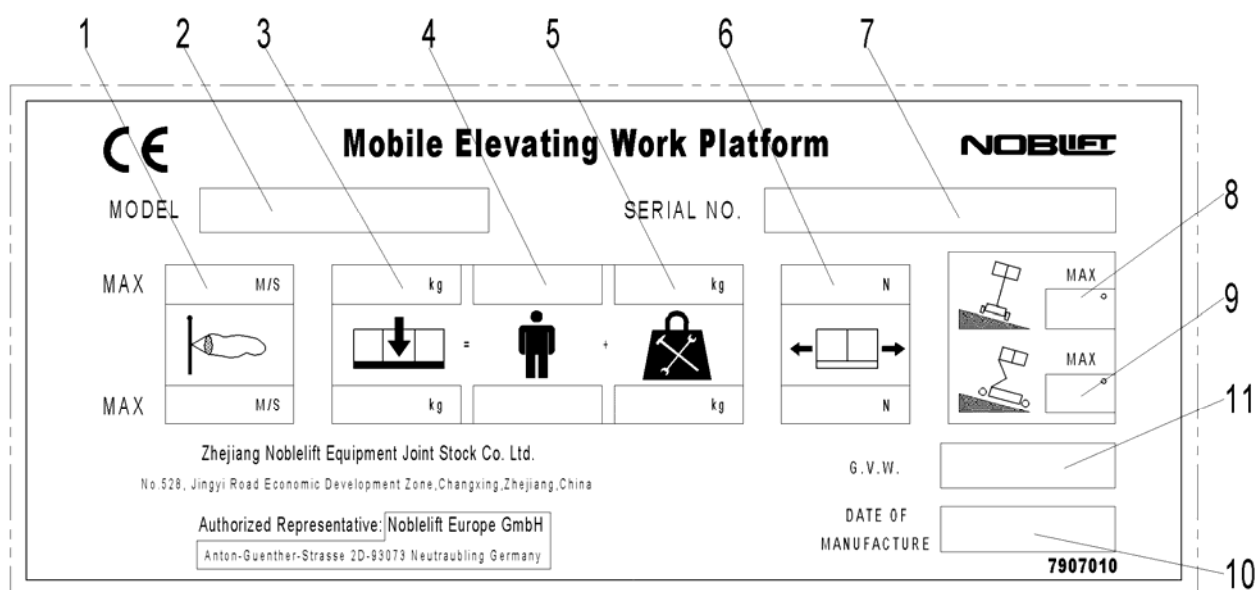
**3. Turtle speed / rabbit speed selection switch** - the toggle switch for selecting turtle speed forward and backward or forward and backward rabbit speed, choose a function, the switch must be moved to the correct direction to start the function.

**4. Meter Display** - to display a series of state in present of machine.

**5. Control Pole** - it used to control three function: lift、steer、drive. After selecting one of the function, control this switch to use the machine.

**6. Emergency Stop Switch** - A two-position, red, mushroom-shaped emergency stop switch functions to provide power to the platform control station and also to turn off power to the platform function controls in the event of an emergency. With the Power selector switch positioned to platform, power is turned on by pulling the switch out (on), and is turned off by pushing the switch in (off).

### 3.5 SIGNS



**Figure 3-4 ID-plate**

- 1 this product allows a maximum wind speed
- 2 this product model
- 3 this product rated load
- 4 the product is rated occupant number
- 5 this product is rated equipment quality
- 6 this product allows a maximum hand operating force
- 7 the product serial number
- 8 this product allows the maximum lateral inclination
- 9 this product allows the maximum slope
- 10 the product serial number
- 11 of the weight of the total product

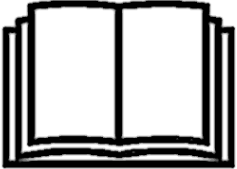


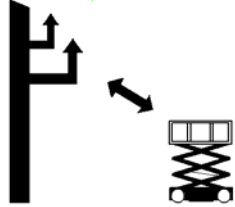
	<p>Please read the operation manual</p>		<p>Risk of electric shock</p>
	<p>Warning</p>		<p>To maintain the required clearance</p>

Figure 3-5 Warning signs and meaning



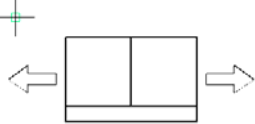
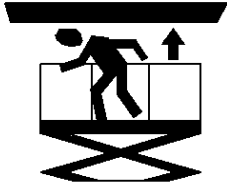

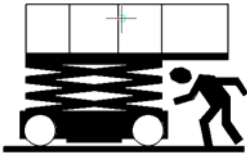




 <p><b>MAX=0m/s</b></p>	<p>Maximum wind speed is zero</p>	 <p><b>MAX=12.5m/s</b></p>	<p>The maximum allowed speed</p>
 <p><b>MAX = 200N</b></p>	<p>The maximum allowed hand operating force</p>		<p>Squeeze collision risk</p>
	<p>Safety belt fixed point</p>		<p>Breaking pressure hazard</p>
<p><b>MAX 460 kg=</b>   <b>+300kg</b></p>  <p><b>MAX 113 kg=</b>   <b>+33kg</b></p>	<p>The maximum allowable load</p>	 <p>1207007</p>	<p>Squeeze the hand of danger</p>

Figure 3-5 Warning signs and meaning

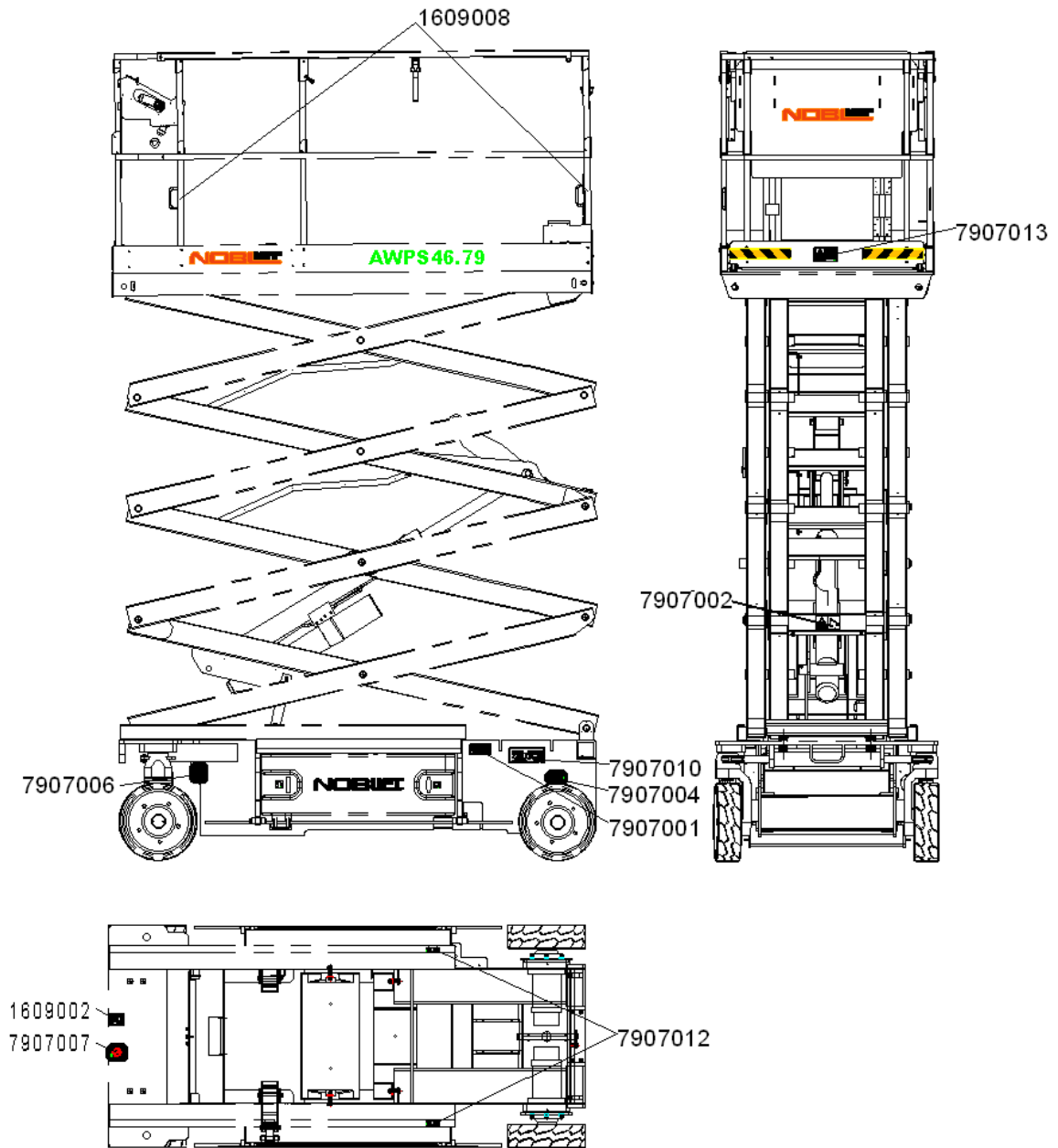
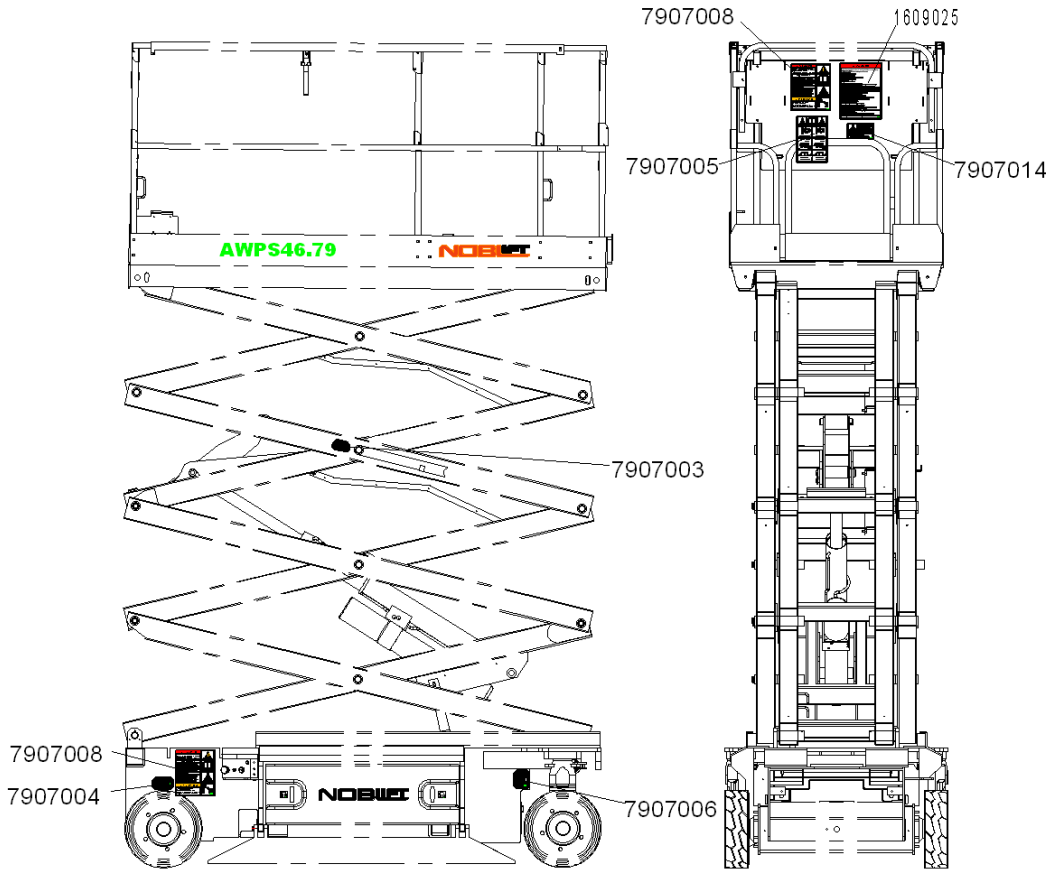


Figure 3-6 The position of the label



7907001

7907002

7907003

7907004

1609002

7907012

1609008

7907010

7907008

1609025

7907005

7907014

7907013

7907006

7907007

Figure 3-6 The position of the label legend

## 4. MACHINE OPERATION

### 4.1 DESCRIPTION

This machine is a self-propelled aerial work platform on top of an elevating 'scissor' mechanism. The Scissor Lift's intended purpose is to position personnel with their tools and supplies at positions above ground level. The machine can be used to reach work areas located above machinery or equipment positioned at ground level.

The Scissor Lift has a primary operator Control Station in the platform. From this Control Station, the operator can drive and steer the machine in both forward and reverse directions, raise and lower the platform and, if equipped, operate the powered deck extension. The machine has a Ground Control Station which will override the Platform Control Station. Ground Controls operate lift up and down. Ground Controls are to be used only in an emergency to lower the platform to the ground should the operator in the platform be unable to do so.

**NOTE:** All platform extension capacities are 250 lb (120 kg).

### 4.2 OPERATION

#### Platform/Ground Select Switch

The power selector switch functions to direct electrical power to the desired control station. With the switch in the ground position, power is supplied to the emergency stop switch at the ground control station. When the switch is in the platform position, power is supplied to the emergency stop switch at the platform control station. The switch should be in the off position when parking the machine overnight.

#### Emergency Stop Switch

This switch, when in the on (out) position, provides electrical power to the ground controls or platform controls, as applicable. In addition, the switch can be used to turn off power (push the switch IN) to the function controls in the event of an emergency.

### 4.3 RAISING AND LOWERING



**ONLY RAISE PLATFORM ON A FIRM, LEVEL AND SMOOTH SURFACE FREE OF OBSTRUCTIONS AND HOLES.**

**NOTE:** When selecting between the Lift/Drive functions, the controller must be in the neutral position for 3 seconds before the function change is effective. The machine is inoperable at this point.

## Raising

1. If the machine is shut down, place the power selector switch to the desired position (platform or ground).
2. Position the applicable emergency stop switch to the "ON" position.
3. If operating from the ground controls, position the lift switch to up and hold until desired elevation is achieved. If operating from the platform controls, select lift function, squeeze and hold the red trigger switch, move the controller backward (up) and hold until desired elevation is reached. The lift switch works in conjunction with the enable switch. Releasing the trigger switch will stop the function being operated.

## Lowering



**ENSURE SCISSOR ARM AREA IS FREE OF PERSONNEL PRIOR TO LOWERING PLATFORM.**

**NOTE:** The machine is equipped with a descent alarm which will sound as the platform is being lowered (CE Optional).

If operating from the ground controls, position the lift switch to down and hold until desired elevation is achieved or until platform is fully lowered. If operating from the platform controls, select lift function squeeze the red trigger switch and push the controller forward (down) and hold until desired elevation is reached or until platform is fully lowered. The lift switch works in conjunction with the enable switch. Releasing the trigger switch will stop the function being operated.

## Arm Guards (If equipped)

If the machine is equipped with arm guards, the platform will stop lowering and an alarm will sound once it has reached a preset height. At this point, the trigger switch and controller must be released before the lowering function can begin again.



**DO NOT 'LOWER' WITHOUT COMPLETELY RETRACTING THE PLATFORM EXTENSION.**

## Platform Extension

The machine is equipped with a mechanically extendable deck, giving the operator better access to worksites. On the AWPS23.56 this extension adds 3 ft (0.9 m) and on the AWPS46.79 and AWPS46.96 the extension adds 4 ft (1.2 m) to the front of the platform. To extend the deck, pull out handles from latch and swing up, then use the handles and handrail to push the extendable deck out. To retract the deck, pull out the handles from latch and swing up, use the handles and handrail to pull and retract the deck. Be sure the handles are in place after the deck is



retracted. Maximum capacity of the deck extension is 250 lbs (120 kg).

**⚠ WARNING**

**Extension of the platform in the closed or extended must use this handle lock.**

**Fold-Down Rails**

**⚠ WARNING**

**DO NOT RAISE PLATFORM WITH RAILS FOLDED DOWN. THE RAILS MUST BE IN THE UPRIGHT POSITION AND PROPERLY PINNED WHEN RAISING THE PLATFORM.**

**NOTE:** *The rails must only be folded down when the machine is in the stowed (fully lowered) position.*

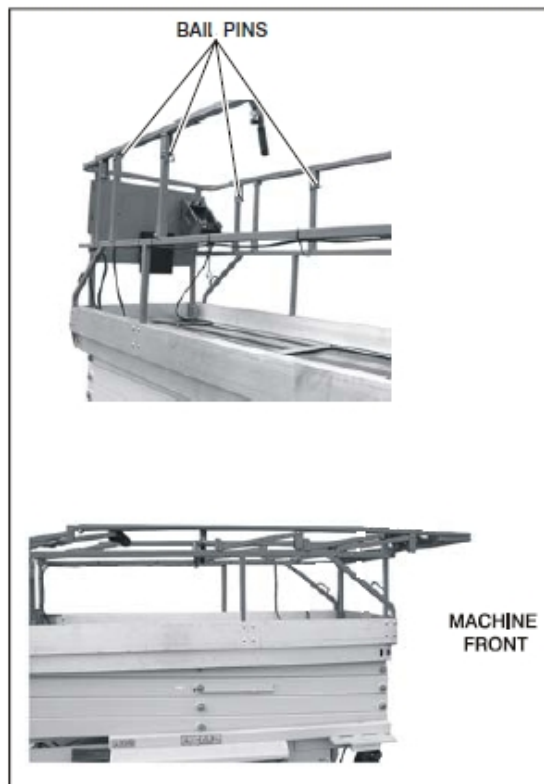
**NOTE:** *Ensure that the drywall gate at the rear of the machine is up and locked in position. Platform control box should be removed and placed on the platform with rails folded down.*

1. To fold down the rails, remove the 4 bail pins at the two front corners and center of the rails.
2. Taking a firm hold on the top rails, carefully push forward and lower until the top rail rests on the middle rail. 4.5 DRIVING

**⚠ WARNING**

**AFTER THE RAILS HAVE BEEN FOLDED DOWN, USE EXTREME CAUTION WHEN EXITING AND ENTERING THE PLATFORM.**

3. To raise the rails back to the upright position, firmly pull the rails toward the back of the machine and replace the bail pins into the rails. Return drywall gate to the lowered position.



## 4.4 STEERING

To steer the machine, the thumb operated steer control switch on the controller handle is positioned to the right for traveling right, or to the left for traveling left. When released, the switch will return to the center-off position and the wheels will remain in the previously selected position. To return the wheels to the straightened position, the switch must be activated in the opposite direction until the wheels are centered.

## 4.5 DRIVING

### **⚠ WARNING**

**DO NOT DRIVE WITH PLATFORM RAISED EXCEPT ON A SMOOTH, FIRM AND LEVEL SURFACE FREE OF OBSTRUCTIONS AND HOLES.**

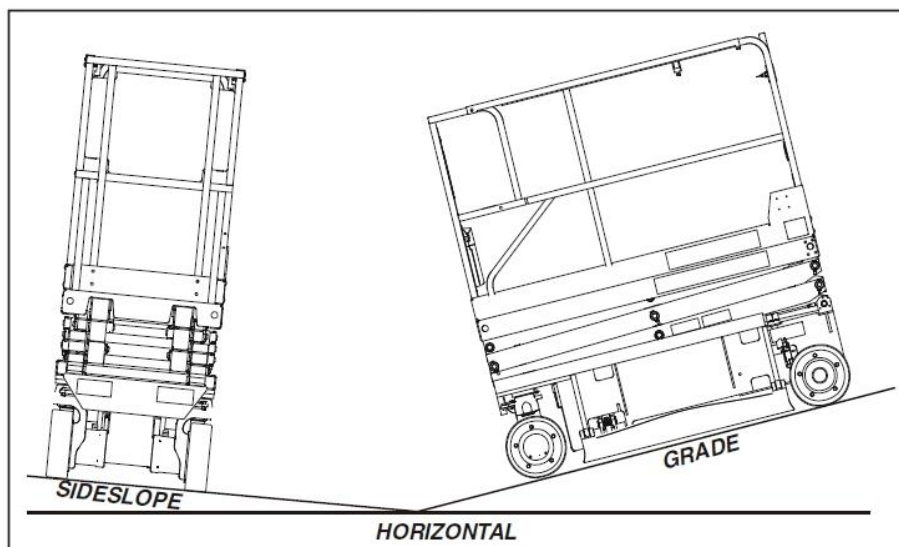
**TO AVOID LOSS OF TRAVEL CONTROL OR UPSET ON GRADES AND SIDESLOPES, DO NOT DRIVE MACHINE ON GRADES OR SIDESLOPES EXCEEDING THOSE SPECIFIED. REFERENCE FIGURE 4-1., GRADE AND SIDESLOPE.**

### Driving Forward

1. Place power selector switch at ground control station to "Platform."
2. Position emergency stop switch at platform control station to "On" position.
3. Select "Drive" on the drive/lift select switch.
4. Squeeze controller (joystick), depressing red trigger on front of joystick, and move joystick forward for duration of travel. The drive system is proportional so for additional drive speed, push the joystick further in the direction of travel. Releasing the trigger will stop the function being operated.

### Driving in Reverse

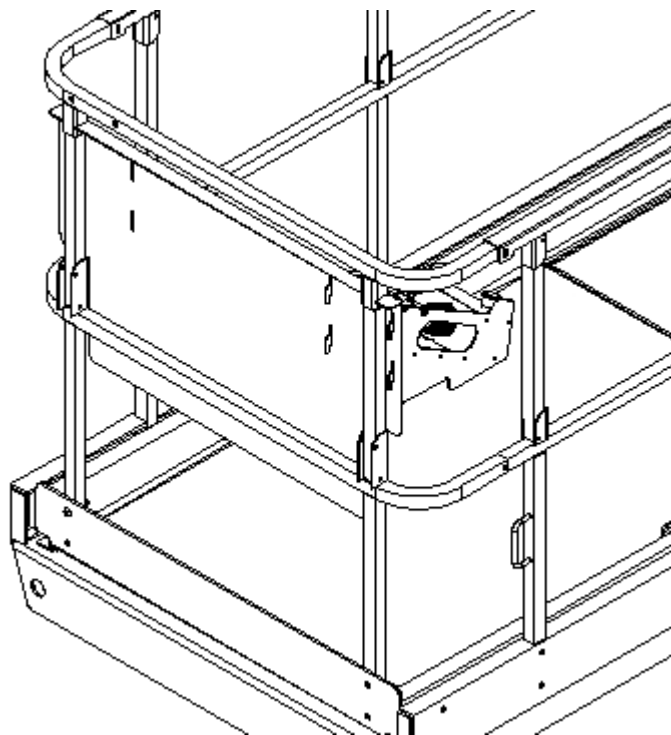
1. Position power selector switch at ground control station to "Platform."
2. Position emergency stop switch at platform control station to "On" position.
3. Squeeze joystick, depressing red trigger on front of joystick, and move joystick backward (reverse) for duration of travel. The drive system is proportional so for additional drive speed, push the joystick further in the direction of travel. Releasing the trigger will stop the function being operated.



## 4.6 PARKING AND STOWING

Park and stow the machine as follows:

1. Drive the machine to a reasonably well-protected and well-ventilated area.
2. Ensure the platform is fully lowered.
3. Position the emergency stop switch to the "Off" position.
4. If necessary, cover the instruction placards, caution and warning decals so that they will be protected from hostile environment.
5. Chock at least two wheels when parking the machine for an extended period of time.
6. Turn the power selector switch to "Off" and remove the key to disable the machine and prevent unauthorized use. The platform control station can also be secured to it's mounting plate, see Figure 4-2.



**Figure 4-2. Securing Control Station to Platform**

## 4.7 BATTERY CHARGING

### Operation

**NOTE:** *Be sure that machine is parked in a well ventilated area before charging begins.*



**ONLY PLUG THE CHARGER INTO A PROPERLY INSTALLED AND GROUNDED OUTLET. DO NOT USE GROUND ADAPTORS OR MODIFY PLUG. DO NOT TOUCH NON-INSULATED PORTION OF OUTPUT CONNECTOR OR NON-INSULATED BATTERY TERMINAL.**

**ALWAYS DISCONNECT THE AC SUPPLY BEFORE MAKING OR BREAKING THE CONNECTIONS TO THE BATTERY BEFORE CHARGING.**

**DO NOT OPEN OR DISASSEMBLE CHARGER.**

**DO NOT OPERATE CHARGER IF THE AC SUPPLY CORD IS DAMAGED OR IF THE CHARGER HAS RECEIVED A SHARP BLOW, BEEN DROPPED, OR OTHERWISE DAMAGED IN ANY WAY.**

The battery charger receptacle is located at the right rear of the machine near the ground control panel.

1. Connect the charger to a grounded outlet.
2. On the Battery Charger, the charger will automatically turn on and go through a short LED indicator self-test. All LED's will flash in an up and down sequence for two seconds.
3. The batteries are fully charged when green light on the battery charger status panel is illuminated.

**NOTE:** *If the charger is left plugged in, the charger will automatically restart a complete charge cycle if the batteries voltage drops below a minimum voltage or 30 days has elapsed.*

### Battery Charger Fault Codes

If a fault occurred during charging, the red "Fault" LED will flash with a code. The number of flashes corresponds to the error. Refer to Table 4-1, Battery Charger Flash Codes.

**Table 4-1. Battery Charger Flash Codes**

Flash(s)	Fault	Fault Removal
1	Battery voltage high	Auto-recover - Indicates a high battery pack voltage
2	Battery voltage low	Auto-recover - Indicates either a battery pack failure, battery pack not connected to charger or battery volts per cell is less than 0.5 VDC. Check the battery pack and connections
3	Charge time-out	Indicates the batteries did not charge in the allowed time. This could occur if the batteries are a larger capacity than the algorithm is intended for or if the batteries are damaged old or in poor condition.
4	Check battery	Indicates the batteries could not be trickle charged up to the minimum voltage per cell level required for the charge to be started.
5	Over-temperature	Auto-recover - Indicates charger has shut down due to high internal temperature
6	QuiQ fault	Indicates that the battery will not accept charge current, or an internal fault has been detected in the charger. This fault will nearly always be set within the first 30 seconds of operation. Once it has been determined that the batteries and connections are not faulty and fault 6 is again displayed after interrupting AC power for at least 10 seconds, the charger must be brought to a qualified service depot.

## 4.8 PLATFORM LOADING

The platform maximum rated load capacity is shown on a placard located on the platform and is based upon the following criteria:

1. The machine is positioned on a firm, uniform surface.
2. All braking devices are engaged.
3. Refer to Section 6 for the maximum platform capacity.

**NOTE:** *It is important to remember that the load should be evenly distributed on the platform. The load should be placed near the center of the platform when possible.*

## 4.9 SAFETY PROP

### **⚠ CAUTION**

**THE SAFETY PROP MUST BE USED WHENEVER MAINTENANCE PERFORMED ON THE MACHINE REQUIRES THE SCISSOR ARMS TO BE RAISED AND ONLY WITH NO LOAD IN THE PLATFORM.**

To engage the safety prop, raise the platform, swing the safety prop from its stowed position located on the right side of the machine. Lower the platform until the safety prop rests on the designated safety prop rest.

To store the safety prop, raise the platform, swing the safety prop around and restore it back to its stowed position.

## 4.10 TIE DOWN/LIFT LUGS

When transporting the machine, the platform extension must be fully retracted and the platform fully lowered in the stowed mode with the machine securely tied down to the truck or trailer deck. There are two tie-down/lift lugs located at the rear of the machine for lifting and tying down. There is a single tie-down lug at the front of the machine. This lug is designed for tying down only. Do not attempt to lift machine from the front lug.

### **⚠ CAUTION**

**LIFTING THE MACHINE FROM THE SIDES USING A FORK TRUCK IS NOT RECOMMENDED BY NOBLIFT. IN THE EVENT THAT THE MACHINE NEEDS TO BE LIFTED FROM THE SIDES CAUTION MUST BE USED TO AVOID JAMMING THE POT HOLE PROTECTION BARS UP AGAINST THE FRAME.**

**EVERY TIME THE MACHINE IS LIFTED FROM THE SIDE, BE SURE AND TEST THE POT HOLE PROTECTION SYSTEM BEFORE THE MACHINE IS PUT BACK INTO OPERATION.**

## 4.11 LIFTING

In the event that the machine must be lifted, there is a forklift pocket located at the rear of the machine. The machine can also be lifted using a proper spreader bar and straps/chains. Reference Figure 4-3., Lifting and Tie Down Diagram.

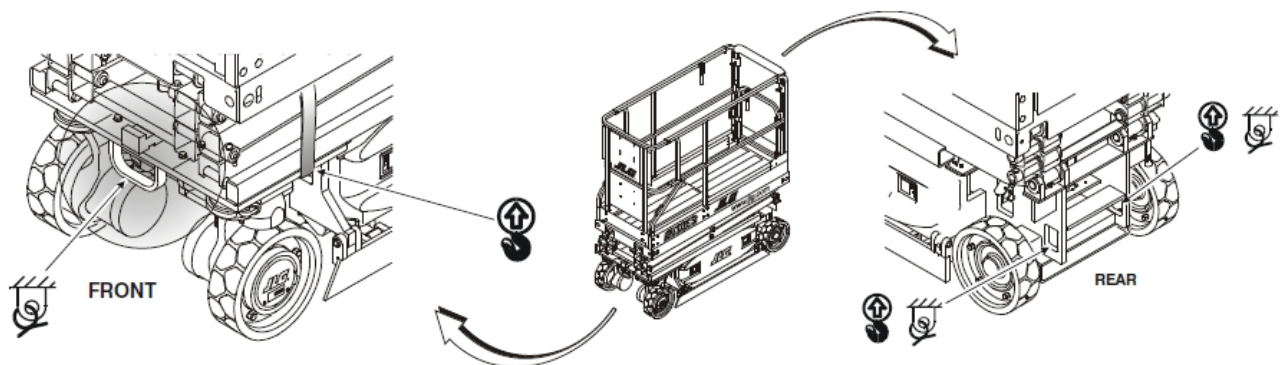


Figure 4-3. Lifting and Tie Down Diagram

## 4.12 TOWING

It is not recommended that this machine be towed, except in the event of an emergency such as a machine malfunction or a total machine power failure.

**NOTE:** *The machine may be equipped with a remote electric brake release, a push button electric brake release, or both styles of electric brake release.*

### **WARNING**

**RUNAWAY VEHICLE/MACHINE HAZARD. MACHINE HAS NO TOWING BRAKES, TOWING VEHICLE MUST BE ABLE TO CONTROL MACHINE AT ALL TIMES. ON-HIGHWAY TOWING NOT PERMITTED. FAILURE TO FOLLOW INSTRUCTIONS COULD CAUSE SERIOUS INJURY OR DEATH.**

**MAXIMUM TOWING SPEED 5 MPH (8 KPH) FOR NO FURTHER THAN 60 FEET (18 M).**

**MAXIMUM TOWING GRADE 25%.**

### **Remote Electric Brake Release**

1. Chock wheels or secure machine with tow vehicle.
2. Pull the emergency stop switch out and position the keyswitch to ground mode.
3. The brake release cable hangs on a hook in the battery compartment on the opposite side of the ground control panel.
4. Locate brake release plug near the analyzer plug at the left front corner of the machine and plug the release cable into the plug.
5. Depress switch to release brakes.
6. When finished towing; release switch, unplug release switch and return brake switch to the proper storage area in the battery compartment.

### **Push Button Electric Brake Release**

**NOTE:** *The push button electric brake release is located on the right side of the machine just forward of the ground control box.*

1. Chock wheels or secure machine with tow vehicle.
2. Pull the emergency stop switch out and position the keyswitch to ground mode.
3. Push the button once to release the brakes.
4. To reset the brakes, push the button again, or push in the emergency stop switch, or take the ground control keyswitch out of the ground mode position.

## 5. EMERGENCY PROCEDURES

### 5.1 GENERAL

This section provides information on the procedures to be followed and on the systems and controls to be used in the event an emergency situation is encountered during machine operation. Prior to operation of the machine and periodically thereafter, the entire operating manual, including this section, should be reviewed by all personnel whose responsibilities include any work or contact with the machine.

#### Emergency Stop Switch

These large red buttons, one located at the Ground Control Station and one at the Platform Control Station, will immediately stop the machine when depressed.

#### **⚠ WARNING**

**CHECK MACHINE DAILY TO MAKE SURE EMERGENCY STOP BUTTON IS IN PLACE AND THAT GROUND CONTROL INSTRUCTIONS ARE IN PLACE AND LEGIBLE. GROUND CONTROL STATION**

The Ground Control Station is located on the left side of the machine frame. The controls on this panel provide the means for overriding the platform controls and for controlling the platform lift up and down functions from the ground. Place the power select switch in the ground position and operate the lift switch to lift up or down.

#### Manual Descent

The manual descent valve is used, in the event of total power failure, to lower the platform using gravity. The manual descent handle is located at the rear of the machine, above the left rear wheel. The handle is connected, by a cable, to the manual descent valve on the lift cylinder. Pulling the manual descent handle opens the valve spool, lowering the platform.

### 5.2 EMERGENCY OPERATION

#### Use of Ground Controls

#### **NOTICE**

**KNOW HOW TO USE THE GROUND CONTROLS IN AN EMERGENCY SITUATION.**

Ground personnel must be thoroughly familiar with the machine operating characteristics and the ground control functions. Training should include operation of the machine, review and understanding of this section and hands-on operation of the controls in simulated emergencies.

#### Operator Unable to Control Machine



1. Operate the machine from ground controls **ONLY** with the assistance of other personnel and equipment (cranes, overhead hoists, etc.) as may be required to safely remove the danger or emergency condition.
2. Other qualified personnel on the platform may use the platform controls. **DO NOT CONTINUE OPERATION IF CONTROLS DO NOT FUNCTION NORMALLY.**
3. Cranes, forklift trucks or other equipment which may be available are to be used to remove platform occupants and stabilize motion of the machine in case machine controls are inadequate or malfunction when used.

## Platform Caught Overhead

If the platform becomes jammed or snagged in overhead structures or equipment, do not continue operation of the machine from either the platform or the ground until the operator and all personnel are safely moved to a secure location. Only then should an attempt be made to free the platform using any necessary equipment and personnel. Do not operate controls to cause one or more wheels to leave the ground.

## Righting of Tipped Machine

A forklift of suitable capacity or equivalent equipment should be placed under the elevated side of the chassis, with a crane or other suitable lifting equipment used to lift the platform while the chassis is lowered by the forklift or other equipment.

## Post-Incident Inspection

Following any incident, thoroughly inspect the machine and test all functions first from the ground controls, then from the platform controls. Do not lift above 10 feet (3 meters) until you are secure that all damage has been repaired, if required, and that all controls are operating correctly.

## 6. GENERAL SPECIFICATIONS AND OPERATOR MAINTENANCE

### 6.1 INTRODUCTION

This section of the manual provides additional necessary information to the operator for proper operation and maintenance of this machine.

The maintenance portion of this section is intended as information to assist the machine operator to perform daily maintenance tasks only, and does not replace the more thorough Preventive Maintenance and Inspection Schedule included in the Service and Maintenance Manual.

### 6.2 OPERATING SPECIFICATIONS

**Table 6-1. Operating Specifications**

Model	AWPS23.56	AWPS46.79	AWPS46.96
Maximum Stowed Travel Grade (Gradeability)- Refer to Figure 4-1	25%	25%	25%
Maximum Stowed Travel Grade (Sideslope) - Refer to Figure 4-1	2°	2°	2°
Maximum Platform Height	18.4 ft 5.6 m	26 ft 7.9 m	31.5 ft 9.5 m
Maximum Tire Load:	1365 lb (620 kg)	2070 lb (939 kg)	2070 lb (939 kg)
Ground Bearing Pressure	109 psi (7.7 kg/cm <sup>2</sup> )	87 psi (6.1 kg/cm <sup>2</sup> )	87 psi (6.1 kg/cm <sup>2</sup> )
Maximum Drive Speed	2.5 mph (4. kmh)	2.5 mph (4 kmh)	2.5 mph (4 kmh)
Maximum Wind Speed	28 mph (12.5 m/s)	28 mph (12.5 m/s)	28 mph (12.5 m/s)

**Table 6-1. Operating Specifications**

Model	AWPS23.56	AWPS46.79	AWPS46.96
Maximum Horizontal Manual Side Force:	100 lb force (445 N)	150 lb force (667 N)	150 lb force (667 N)
Maximum Hydraulic Pressure	1800 psi 12.5Mpa	2000 psi 14Mpa	2000 psi 14Mpa
Inside Steer Angle	56°	56°	56°
Outside Steer Angle	42°	42°	42°
Minimum Steer radius	2.5M	3.5M	3.5M
Electrical System Voltage (DC)	24V	24V	24V
Approximate Gross Machine Weight	1390 Kg	2706 Kg	2730 Kg
Lift/down time (S)	28/30	44/50	65/73
Ground Clearance with pot hole protection system down	0.75in (1.9 cm)		
Ground Clearance with pot hole protection system up	3.87 in (9.8cm)	6.19in (12.7cm)	

**Table 6-2. Platform Capacities**

MODEL	CE		CE Extensions platform	
	Max Capacity	Max Persons	Max Capacity	Max Persons
AWPS23.56	230 kg	2	113 kg	1
AWPS46.79	460 kg	2	113 kg	1
AWPS46.96	460 kg	2	113 kg	1

**Dimensional Data**

**Table 6-3. Dimensions**

MODEL	AWPS23.56		AWPS46.79		AWPS46.96	
	feet	meter	feet	meter	feet	meter
Unit of Measure						
Platform Height - Elevated	18.5	5.6	26	7.9	31.16	9.5
Platform Height - Stowed	3.1	0.96	4	1.2	4	1.2
Working Height	25	7.6	32	9.8	38	11.6
Overall Stowed Machine Height - Rails Up	6.5	2	7.9	2.4	7.9	2.4
Overall Stowed Machine Height - Rails Collapsed	N/A	N/A	6.4	1.9	6.4	1.9
Rail Height (From platform floor)	3.25	1	3.25	1	3.25	1
Overall Machine Width	2.5	0.76	3.8	1.2	3.8	1.2
Overall Machine Length - Deck Retracted	6.2	1.9	8.2	2.5	8.2	2.5
Overall Machine Length - Deck Extended	9	2.8	12.4	3.8	12.4	3.8
Platform Size - Length	6.1	1.9	8.2	2.5	8.2	2.5
Platform Size - Maximum Length	9.11	2.78	12.3	3.75	12.3	3.75
Platform Size - Width	2.5	0.76	3.7	1.1	3.7	1.1
Platform Extension Length	3	0.9	4.2	1.3	4.2	1.3
Wheelbase	5.2	1.6	6.8	2	6.8	2

**Motors**

**Drive Motor**

Excitation type : 4 Terminals separate 24V DC Power: 1500w 2600rpm

**Figure 6-1 Cricuit diagram**

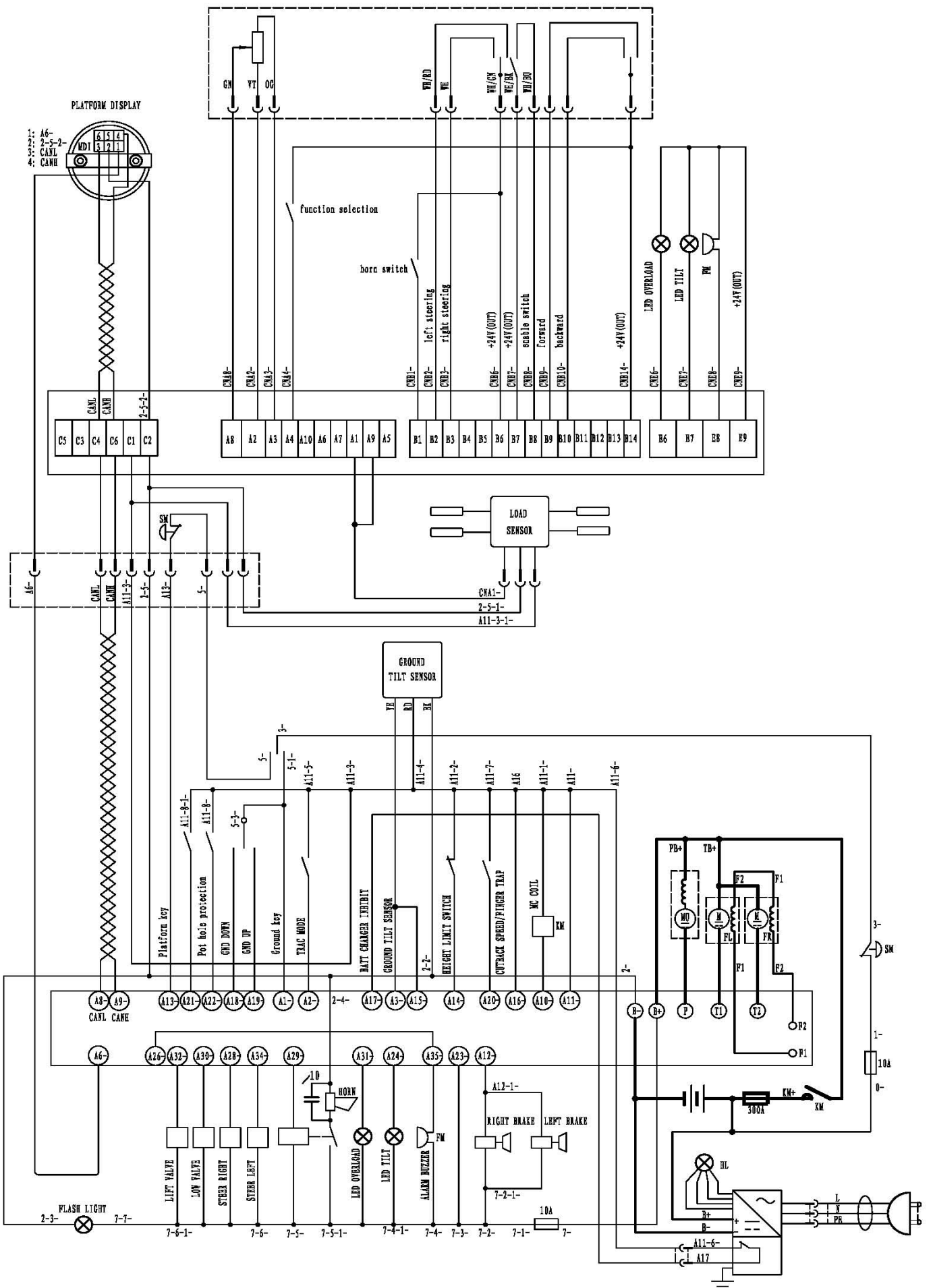
**Hydraulic Pump/Electric Motor Assembly (All Models)**

Type: Series Wound Permanent Magnet 24V DC Power: 3kW

**Batteries**

**Table 6-4. Battery Specifications**

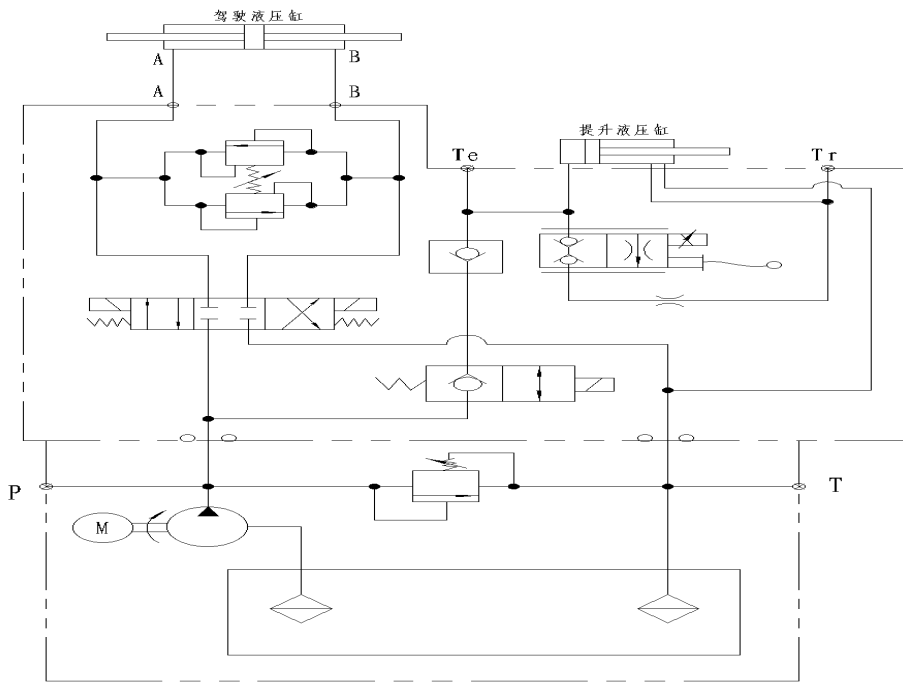
Voltage	6 V per battery
Amp Hour (Standard Battery)	210 Amp



## Capacities

**Table 6-5. Capacities**

Model	AWPS23.56	AWPS46.79	AWPS46.96
Hydraulic Tank	6 L	6 L	7 L
Hydraulic System (Including Tank)	8.3 L	12.5L	14.2L



**Figure 6-2 hydraulic principal**

## Tires

**Table 6-6. Tire Specifications**

Model	AWPS23.56	AWPS46.79	AWPS46.96
Size	323mm x 100mm	406 mm x 125 mm	
Max Tire Load	2500 lbs (1134 kg)	4000 lbs (1814 kg)	
Wheel Bolt Torque	142-163 Nm		

## 6.3 CRITICAL STABILITY WEIGHTS



**DO NOT REPLACE ITEMS CRITICAL TO STABILITY, SUCH AS BATTERIES OR SOLID TIRES, WITH ITEMS OF DIFFERENT WEIGHT OR SPECIFICATION. DO NOT MODIFY UNIT IN ANY WAY TO AFFECT STABILITY.**

**Table 6-7. Critical Stability Weights**

Component	AWPS23.56	AWPS46.79	AWPS46.96
Wheel and Tire Assembly (each)	22 lbs (9.8 kg)	42 lbs (19 kg)	

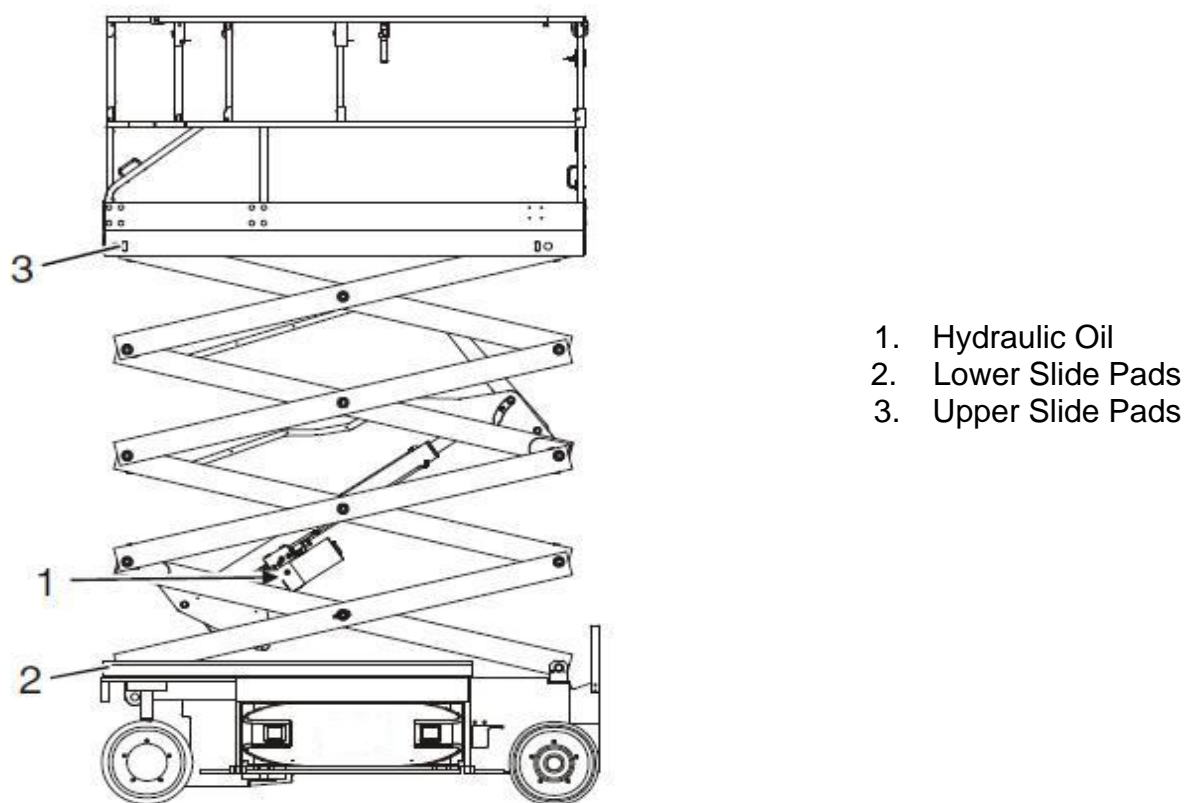
Wheel/Tire and Drive Assembly (each)	117 lbs (53 kg)	162 lbs (73.4 kg)	
Lift Cylinder	176 lbs(80 kg)	263 lbs (119 kg)	283 lbs (128 kg)
Batteries: (each) 220 Amp	66 lbs (30 kg)	66 lbs (30 kg)	

## Lubrication

**NOTE:** Aside from recommendations, it is not advisable to mix oils of different brands or types, as they may not contain the same required additives or be of comparable viscosities.

Please check the oil level every six months. The oil can be hydraulic oil: ISO VG32, its viscosity should be 30cSt at 40<sup>0</sup> C.

## 6.4 OPERATOR MAINTENANCE



**Figure 6-3. Lubrication Diagram**

### Oil Check Procedure (1)

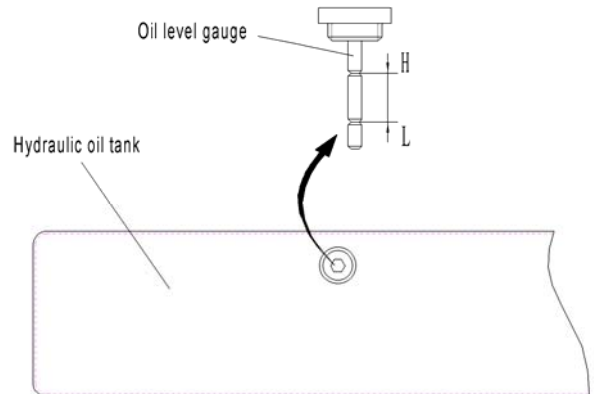
Lube Point(s) - Fill Plug    Lube - Hydraulic Oil    Interval - Every 6 months

1. With the scissor lift on a flat and level surface and the platform empty, elevate machine and swing safety prop out of it's stowed position.
2. Continue to elevate the platform until the fill plug, located on the right side of the tank attached to the lift cylinder, is fully accessible.
3. Wipe all dirt and debris from the filler plug area.

4. Slowly remove the fill plug venting any pressure that may be built up in the reservoir.

5. To check the oil level, lower platform so it rests on the safety prop. The use of level gauge check the hydraulic oil level, when the oil level in H and L between, hydraulic oil quantity in a suitable range.

Vehicle type	H	L
AWPS23.56	8.3L	7.8L
AWPS46.79	12.5L	12L
AWPS46.96	14.2L	13.7L



**! CAUTION**

ENSURE THE SCISSOR ARMS ARE PROPERLY SUPPORTED

**NOTE:** The AWPS46.79/AWPS46.96 platforms will have to be raised higher than the AWPS23.56 in order to access the oil plug.

**! CAUTION**

THERE MAY BE UP TO 10 PSI OF PRESSURE IN THE TANK.

**! CAUTION**

First come on, can mix oil tank filled with, and then pick up platform about 2 ~ 3 meters or so, continue refueling. Oil capacity can see table 6-5 capacity.

6. With the plug removed, the oil level should be completely full, at the top of the fill port with scissor arms resting on the safety prop. from the fill port.

7. If additional oil is required, add proper grade of oil by using a funnel with a flexible spout or a plastic squeeze bottle. Fill until oil weeps out of opening.

**NOTE:** Care should be taken not to introduce any impurities (dirt, water etc.) while plug is removed.

8. Replace plug and torque to 40 ft lbs (56 Nm).

9. Any time a hydraulic component is removed or replaced, cycle the scissor arms several times and refer to steps 3 and 4 to recheck oil level.

Lower (2) & Upper Slide Pads (3)

Lube - White Lithium Grease  
Interval - Every 6 months

1. With the platform empty, elevate machine and swing safety prop out of its stowed position.

**⚠ CAUTION**

**ENSURE THE SCISSOR ARMS ARE PROPERLY SUPPORTED.**

2. Locate the Lower and Upper Slide Pads and remove all dirt and debris from the slide channel area (1, 2). Refer to Figure 6-2., Lower Slide Pad Channel.
3. Apply a layer of grease along the inside and bottom of the lower slide channel (1) on both sides of the machine.

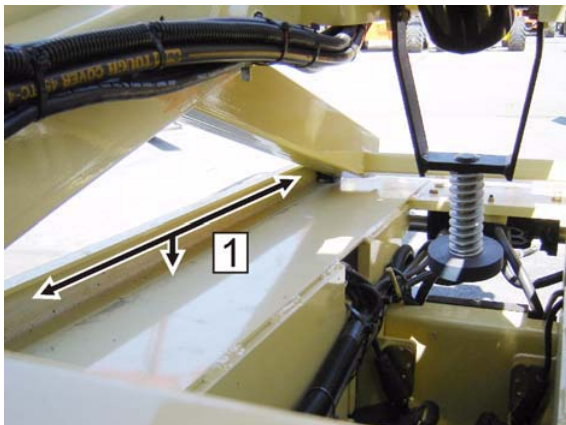


Figure 6-2. Lower Slide Pad Channel

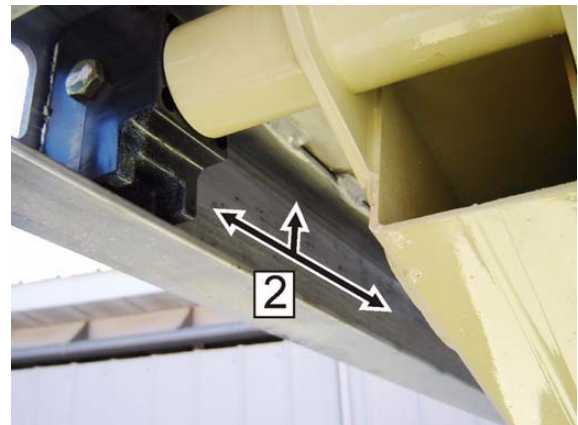


Figure 6-3. Upper Slide Pad Channel

4. Apply a layer of grease along the inside and top of the upper slide channel (2) on both sides of the machine. Refer to Figure 6-3., Upper Slide Pad Channel.

**NOTE:** Recommended lubricating intervals are based on machine operations under normal conditions. For machines used in multi-shift operations and/or exposed to hostile environments or conditions, lubrication frequencies must be increased accordingly.

## 6.5 TIRES AND WHEELS

### Tire Wear and Damage

Inspect tires periodically for wear or damage. Tires with worn edges or distorted profiles require replacement. Tires with significant damage in the tread area or side wall, require immediate evaluation before placing the machine into service.

### Wheel and Tire Replacement

Replacement wheels must have the same diameter and profile as the original. Replacement tires must be the same size and rating as the tire being replaced.

### Wheel Installation



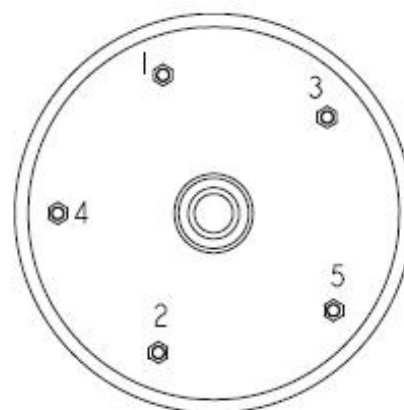
It is extremely important to apply and maintain proper wheel mounting torque.

**⚠ WARNING**

**WHEEL NUTS MUST BE INSTALLED AND MAINTAINED AT THE PROPER TORQUE TO PREVENT LOOSE WHEELS, BROKEN STUDS, AND POSSIBLE SEPARATION OF WHEEL FROM THE AXLE. BE SURE TO USE ONLY THE NUTS MATCHED TO THE CONE ANGLE OF THE WHEEL.**

Tighten the lug nuts to the proper torque to prevent wheels from coming loose. Use a torque wrench to tighten the fasteners. If you do not have a torque wrench, tighten the fasteners with a lug wrench, then immediately have a service garage or dealer tighten the lug nuts to the proper torque. Over-tightening will result in breaking the studs or permanently deforming the mounting stud holes in the wheels. The proper procedure for attaching wheels is as follows:

1. Start all nuts by hand to prevent cross threading. DO NOT use a lubricant on threads or nuts.
2. Tighten nuts in the following sequence.
3. The tightening of the nuts should be done in stages. Following the recommended sequence, tighten nuts per wheel torque.



**Table 6-9. Wheel Torque Chart**

TORQUE SEQUENCE		
1st Stage	2nd Stage	3rd Stage
20-30 ft lbs (28 - 42 Nm)	65-80 ft lbs (91 - 112 Nm)	105 -120 ft lbs (142 - 163 Nm)

4. Wheel nuts should be torqued after the first 50 hours of operation and after each wheel removal. Check torque every 3 months or 150 hours of operation.

The general moments for screwing the hydraulic hose

Thread	Nut Torque (N·m)
M14x1.5	20.7~25.3

**Appendix 1 list of wearing parts**

No.	No.	Name	Quantity	Respective components
1	0000022036	Combination washer 12	2	Valve board components
2	0090000087	O-Shaped ring 7.5x1.8	2	
3	0000025021	Combination washer 10	10	
4	0090000156	O-Shaped ring 8x2.65	2	
5	9000001355	O-Shaped ring 94.84x3.53	1	Lifting cylinder
6	9000001356	Guide ring 60x65x9.7	2	

7	9000001357	Y shape circle 60x70x10	1	
8	9000001358	dust ring 60x68x5/6.5	1	
9	0000022040	O-Shaped ring 35x3.1	1	
10	9000001359	Supporting ring 100x95x9.7	2	
11	9000001360	Sealing ring100x87x8.3	1	
12	9000001361	dust ring 35/43X5/38	2	
13	9000001362	Sealing ring35/45X8	2	
14	9000001363	O-Shaped ring 53.57X3.53	2	
15	9000001364	Block circle	2	
16	9000001365	Sealing ring60/49X4.2	1	
17	9000001366	O-Shaped ring 34.59X2.62	1	
18	9000001367	Block circle	1	pump
19	9000002219	O-Shaped ring	2	
20	9000002236	O-Shaped ring	1	
21	9000002240	Sealing ring	1	
22	9000002247	Sealing ring	1	
23	9000002249	Sealing ring	1	
24	9000002251	Sealing ring	1	
25	9000002252	Sealing ring	1	
26	9000002256	Sealing ring	1	
27	9000002263	filter	1	
28	0090000159	Tapered roller bearings 32209	2	
29	0090000160	Tapered roller bearings 32206	2	

## Appendix 2 Inspection and maintenance records

Date	Note



